

disperator[®] OPTION FOR FOOD WASTE SYSTEM

500A EXCELLENT SERIES - FIXED WATER TRAP

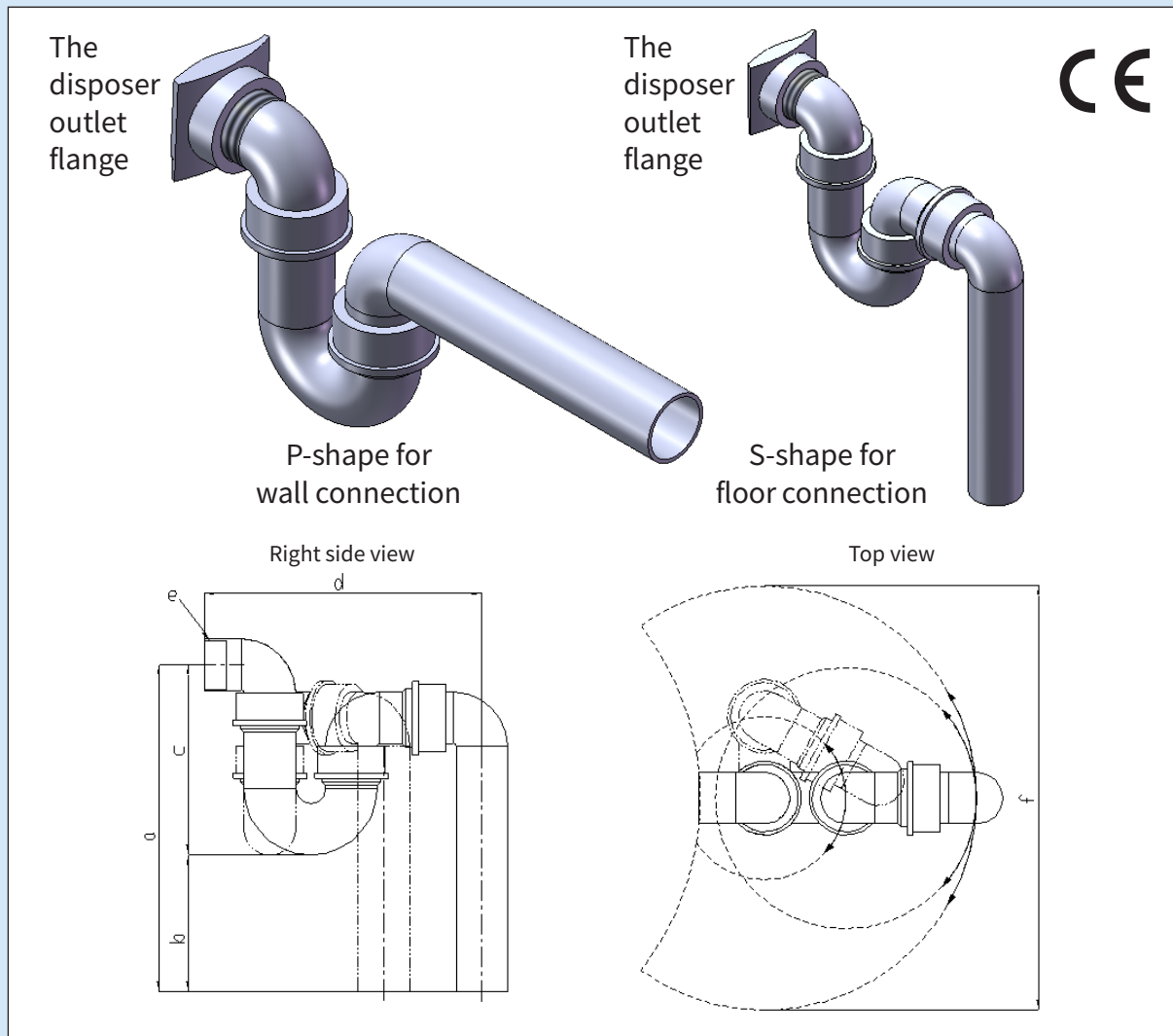

Technical specification

	All measurements in mm							Fixed water trap	
	Material	Art.No.	a	b	c	d	e	f	
G2" (for disposer models 510A, 515A, 520A) with outlet G2 ½"	Plastic	91900000-015	550	315	235	410	G2", ext. thread	520	
G2" (for disposer models 510A, 515A, 520A)	Plastic	91900000-016	550	315	235	410	G2", ext. thread	520	
G2" (for disposer models 510A, 515A, 520A)	Stainless steel AISI 316L / EN1.4404	21900000-000	620	440	185	355	G2", ext. thread	520	
G2 ½" (for disposer models 530A, 550A, 575A)	Plastic	91900000-017	580	220	360	500	G2 ½", ext. thread	720	

Subject to change without notice

Disperator AB

Mälarvägen 9, SE-141 71 Segeltorp
 Tel +46 (8) 724 01 60
 info@disperator.se, www.disperator.se



Ref: Option_Va_en_230627