

disperator® FOOD WASTE DISPOSERS

500A-ATF-K EXCELLENT SERIES



Disperator food waste disposers are used in galleys and kitchens around the world, providing an efficient and immediate removal of food waste whenever it arises. Thereby improving hygiene in the working environment, eliminating bad odors and bacteria formation and minimizing manual handling.

Our product range is designed with the user's needs in focus and meets the modern requirements for handling food waste. The quality grinding unit with hardness from specially cast steel alloy, together with the unique sealing design between grinder and motor, ensure years of reliable operation and low maintenance cost. The disposer's life span is extended further by the outer housing of stainless steel EN 1.4301 (AISI 304) and protection class IP55 or higher for electrical components.

The wide range of disposer sizes makes it easy to adjust any installation to fit any workplace in a galley or kitchen. With an ATF-K assembly installation is simplified as no welding is required when mounting on-site. The unit is installed in the sink's existing drain outlet, with diameter 93 mm, using a screw joint reinforcement. A protection lid covering the disposer inlet prevents access to the

grinding unit during operation, also serving as a splash back protection and reducing the risk of cutlery falling into the disposer by mistake. The lid is fitted with a safety interlock switch which stops the disposer when lifted.

The disposer is delivered complete with all wiring ready from the factory. To easily reach the disposer's start & stop button, they are easily mounted with their enclosure on the included bracket under the kitchen counter. After that, only the disposer's connection cable is connected to the safety switch on the wall, so all electrical installation is complete. The protective cover with circuit breaker is mounted above the grinder inlet in the sink. With the help of hose connections, cold water is easily connected to delivered flushing articles which comply with SS-EN1717. The location of the disposer's outlet can be adjusted to suit the location of the existing drain.

All Disperator Excellent 500-Series of disposers have the Statement of Compliance issued by DNV GL verifying compliance with applicable sections of MARPOL Annex V REGULATIONS FOR THE CONTROL OF POLLUTION BY GARBAGE FROM SHIPS AND PLATFORMS, as amended in 2019.

Disperator AB

Mälärvägen 9, SE-141 71 Segeltorp, Sweden
Tel +46-8-724 01 60
info@disperator.se, www.disperator.se



MADE IN SWEDEN

Ref: 500A_ATF-K_pb_en_260218

disperator® FOOD WASTE DISPOSERS

500A-ATF-K EXCELLENT SERIES

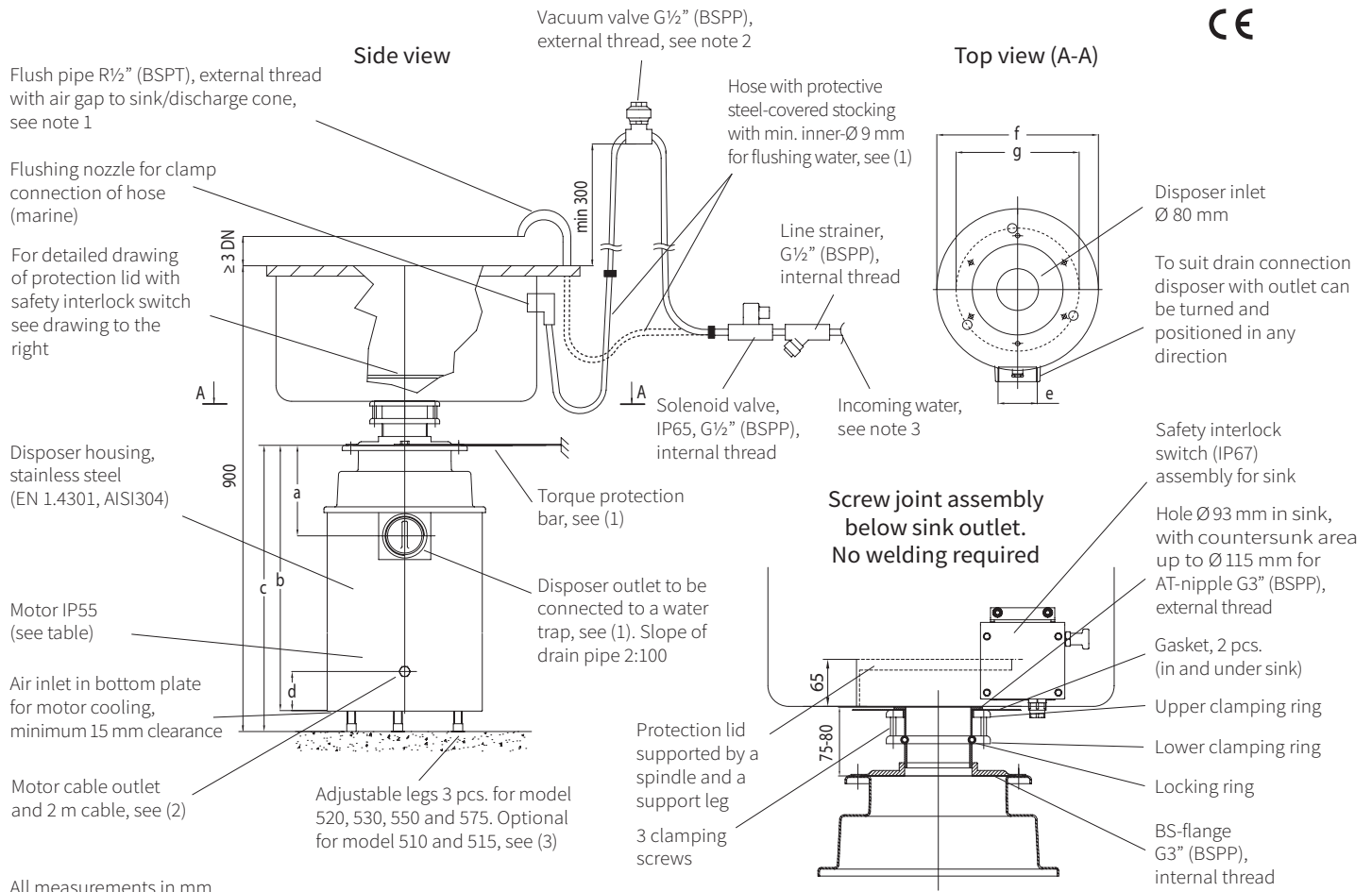

All measurements in mm

Technical Specification	510A	515A	520A	530A	550A	575A
Normal capacity, kg/hr	300	400	500	700	850	1000
Electrical power, kW	0,9	1,25	1,8	2,5	4,0	5,5
Rated current, A to be set on the disposer motor protector for the following voltages:						
400 V / 3 ph. / 50 Hz	2,2	2,7	3,7	5,5	9,0	12,0
440 V / 3 ph. / 60 Hz	2,2	2,7	3,7	5,5	7,5	10,0
480 V / 3 ph. / 60 Hz	2,2	2,7	3,7	5,0	7,5	10,0
Other 3-ph. voltages available.	1-ph. 220-240V, 50/60Hz also available for models 510A and 515A					
Control voltage	For marine installation the same as motor voltage. For land installation 230V / 50Hz.					
Fuse rating, slow	10 A	10 A	10 A	16 A	16 A	16 A
Characteristic for automatic fuse	D (slow)	D (slow)	D (slow)	D (slow)	D (slow)	D (slow)
Gross / net weight, kg	36 / 25	38 / 27	41 / 30	62 / 43	65 / 46	70 / 51
Measurement a	151	151	151	176	176	176
Measurement b	460 see (3)	460 see (3)	583	560 see (4)	560 see (4)	655
Measurement c	See (3)*	See (3)*	583-763	560-740 see (4)	560-740 see (4)	655-835
Measurement d	40	40	40	75	75	75
Measurement e	G2" (BSPP), internal thread			G2 ½" (BSPP), internal thread		
Measurement f	253	253	253	310	310	310
Measurement g (legs)	See (3)	See (3)	204	236	236	236

Note 1: Meeting the requirements as backflow protection for liquid category 5 in EN1717.

Note 2: For marine installations with flushing nozzles in sink/discharge cone, without specified rectangular overflow drain and air gap up to the flushing nozzles, which is required according to SS-EN1717 for liquid category 5.

Note 3: Recommended incoming water pressure 3 - 6 bar.

Subject to change without notice.

(1) Installation material needed but not incl. in standard delivery are:

- main electrical safety switch placed on wall/bulkhead for incoming electricity,
- hose with protective steel-covered stocking (minimum inner- \varnothing 9mm) for cold flush water,
- vacuum valve (marine installation),
- water trap for connection to disposer outlet,
- torque protection bar, for fixing disposer to wall/bulkhead.

Can be ordered from DISPERATOR.

- (2) For connection to start/stop unit including contactor and overload protector (IP66) placed on wall/bulkhead. Start/stop unit to be connected to main electrical safety switch, see (1), but not to earth leakage circuit breaker.
- (3) 3-ph. unit without legs as standard. Legs available as option.
- (4) Short version (b = 525 mm and c = 525-705 mm) and long version (b = 655 mm and c = 655-835 mm) available as option.
- (5) User manual with installation and service instructions, laminated operating instructions and laminated safety instructions as well as electrical documentation are included in delivery.

- (*) 1-ph. unit 510A with or without legs from 460-763 mm.
3-ph. unit 510A with or without legs from 460-763 mm.
1-ph. unit 515A with or without legs from 583-763 mm.

Disperator AB

Mälärvägen 9, SE-141 71 Segeltorp, Sweden
Tel +46-8-724 01 60
info@disperator.se, www.disperator.se

Ref: 500A_ATF-K_pb_en_260218