

**USER MANUAL****FOOD WASTE PROCESSOR  
500A-GTS-E65 EXCELLENT SERIES**

Product Description   Installation   Safety   Operation   Service



## EC DECLARATION OF CONFORMITY

We, the manufacturer: **Disperator AB**  
Mälarvägen 9  
SE-141 71 SEGELTORP  
Sweden  
Phone: +46 - 8 724 0160  
E-mail: info@disperator.se

hereby declare under our sole responsibility that the machinery,

Description: **Disperator Food Waste Processor**  
Model / type: **530A-GTS-E65, 550A-GTS-E65 and 575A-GTS-E65**  
Place of origin: **Segeltorp, Sweden**

to which this EC-Declaration relates, fulfills all the relevant provisions of the Machinery Directive 2006/42/EC and the EMC-Directive 2014/30/EU.

The following harmonized standards have been used:

SS-EN ISO 12100:2010  
SS-EN ISO 13857:2019  
SS-EN 14120:2015  
SS-EN 60204-1:2018  
SS-EN 61000-6-2  
SS-EN 61000-6-3

This declaration relates exclusively to the machinery in the state in which it was placed on the market, and excludes components which are added and/or operations carried out subsequently by the end user.

Segeltorp, Sweden, April 15, 2024  
Disperator AB

  
Johan Anders Wahlström  
CEO

Folder: A1003885  
Document N14240EG  
no:

## Statement of Compliance

This is to verify that the food waste disposer/grinder models included in the product series 500, 500A, 500V, 500RS, 500EX, GTS-E65 and GTS-Mini manufactured by Disperator AB, Sweden, for installation as food waste handling equipment on ships and platforms, are, with respect to the size of the ground food waste, in compliance with MARPOL Annex V REGULATIONS FOR THE CONTROL OF POLLUTION BY GARBAGE FROM SHIPS, as amended in 2019.

Excerpts from applicable regulations:

### Regulation 4

*Discharge of garbage outside special areas*

- 1 Discharge of the following garbage into the sea outside special areas shall only be permitted while the ship is en route and as far as practicable from the nearest land, but in any case not less than:
  - .1 3 nautical miles from the nearest land for food wastes which have been passed through a comminuter or grinder. Such comminuted or ground food wastes shall be capable of passing through a screen with openings no greater than 25 mm.

### Regulation 5

*Special requirements for discharge of garbage from fixed or floating platforms*

- 2 Food wastes may be discharged into the sea from fixed or floating platforms located more than 12 nautical miles from the nearest land and from all other ships when alongside or within 500 m of such platforms, but only when the wastes have been passed through a comminuter or grinder. Such comminuted or ground food wastes shall be capable of passing through a screen with openings no greater than 25 mm.

### Regulation 6

*Discharge of garbage within special areas*

- 1 Discharge of the following garbage into the sea within special areas shall only be permitted while the ship is en route and as follows:
  - .1 Discharge into the sea of food wastes as far as practicable from the nearest land, but not less than 12 nautical miles from the nearest land or the nearest ice shelf. Food wastes shall be comminuted or ground and shall be capable of passing through a screen with openings no greater than 25 mm.

Stockholm, February 26, 2021



Digitally Signed By: Johansson, Roger

Location: DNV GL Stockholm, Sweden

Signing Date: 2021-02-26

Roger Johansson  
Senior Surveyor

If any person suffers loss or damage which is proven to have been caused by any negligent act or omission of the Society, then the Society shall pay compensation to such person for his proven direct loss or damage. However, the compensation shall not exceed an amount equal to ten times the fee charged for the service in question. The maximum compensation shall never exceed USD 2 million. In this provision the "Society" shall mean DNV GL AS as well as all its direct and indirect owners, affiliates, subsidiaries, directors, officers, employees, agents and any other person or entity acting on behalf of DNV GL AS.

© DNV GL 2014. DNV GL AND THE HORIZON GRAPHIC ARE TRADEMARKS OF DNV GL AS.  
Form No.: 40.91a Issue: 2014-07

www.dnvgl.com  
Page 1 of 1

## Table of Contents

<b>1. Safety Precautions</b>	<b>7</b>
1.1. Safety Signs	7
1.2. Personnel Qualifications and Training	8
<b>2. Company Profile</b>	<b>9</b>
<b>3. Product Description and Technical Specification</b>	<b>10</b>
3.1. Food Waste Processor 500A-GTS-E65 EXCELLENT-Series for Free-standing installation	10
3.2. Technical Specification	11
<b>4. Storage and Displacement</b>	<b>14</b>
4.1. Storage of the Machine	14
4.2. Displacement of the Machine	14
<b>5. Included in Delivery</b>	<b>15</b>
5.1. Documentation	15
5.2. Food Waste Processor	15
<b>6. Installation Description for the Machine</b>	<b>16</b>
6.1. Assembly of the Machine	16
6.1.1. Deployment of the Machine	16
6.1.2. Fixation of the Machine	16
6.1.3. Mounting of the Splash Guard	16
6.2. Flushing Water	17
6.2.1. Water Pipe DN15	17
6.2.2. Line Strainer DN15 and Solenoid Valve DN15	17
6.2.3. Hose with Protective Steel-Covered Stocking for Flushing Water, minimum Inner-Ø 9mm	17
6.3. Connection of Pump Outlet to Drain Waste Pipe going to Tank	18
6.3.1. To Check before the Connection is made	18
6.3.2. Specification and Connection of Drain Waste Pipe	18
6.4. Electrical Connection	19
6.4.1. Supply Voltage	19
6.4.2. Mains Fuses	19
6.4.3. Wall/Bulkhead Mounted Electrical Security Breaker	19
6.4.4. Cable Dimension	19
6.4.5. Cable Protection	19
6.4.6. Earth Wire	19
6.4.7. Direction of Rotation for the Disposer and the Pump	20
6.4.8. Protective Cover Connected to Safety Interlock Switch	20
6.4.9. Sensor for Monitoring Pump Temperature	20

6.5. Start Up and Final Testing _____	21
6.5.1. Check before Start Up _____	21
6.5.2. Important Preparations before Starting-up the Machine _____	21
6.5.3. Checks during Start-up _____	21
6.5.4. Setting the Monitoring of the Pump's Temperature _____	21
6.5.5. Final Measures _____	22
<b>7. Installation Instructions for Level Sensors and Overfill Protection in the Tank _____</b>	<b>23</b>
<b>8. Safety Instructions _____</b>	<b>27</b>
<b>9. Operating Instructions _____</b>	<b>28</b>
9.1. Start and stop _____	29
9.2. Daily cleaning of the disposer _____	29
9.3. Trouble Shooting _____	30
9.3.1. Disposer Reduces Speed, Stops or does not Start _____	30
9.3.2. Machine Starts but there is no Flushing Water _____	30
9.3.3. Machine does not Start and makes no Sound _____	30
<b>10. Service Instructions _____</b>	<b>31</b>
10.1. Authorization _____	31
10.2. Exploded View and Spare Parts List for the Disposer _____	32
10.3. Overhaul of Protection Cover with Switch, Assembly and Connections _____	36
10.4. Overhaul and Maintenance of the Pump _____	36
10.5. Dismantling of Disposer _____	37
10.6. Assembly of Disposer _____	40
10.7. Timer control and Settings _____	43
10.8. Overhaul and Maintenance Intervals _____	44

## 1. Safety Precautions







This manual contains instructions for installation, operation and maintenance of the food waste disposer (below also called the machine). It is therefore essential for the installer, union representatives and users of the machine to read the manual thoroughly prior to installation, commissioning, operation and overhaul & maintenance.

This manual must always be at hand where the machine is being used.

It is not only the general safety instructions in this section that need to be considered, but also the other special safety instructions given in this manual.

### 1.1. Safety Signs

The following safety signs are used in this manual and on the machine. Failure to comply with the safety regulations contained in this manual as well as on the machine may cause personal injury or damage the machine.

Read this User Manual before use	
Use protective goggles	
Use ear protection	
Warning for electric voltage	
General personal danger	
Warning for mechanically caused damage (rotating parts)	

**Warning plates located on or close to the machine must always be observed and kept legible.**

## 1.2. Personnel Qualifications and Training

All personnel managing the below tasks for the machine as described in this manual, must have the necessary qualifications to carry out this work. Areas of responsibility, scope of authority and staff supervision must be carefully defined by the machine owner. If the personnel do not have the necessary qualifications for this, they must receive training and instructions. Such training can be provided by the manufacturer / supplier. Moreover, it is the responsibility of the machine owner to make sure that all users read and understand the content of this User Manual.

### Moving the Machine

Staff responsible for moving the machine must have knowledge about the handling of the lifting gear and stopping devices and have knowledge of applicable safety regulations for these. If they lack this knowledge, they must receive the required training.

### Installation

Personnel responsible for the installation of the machine must have knowledge equivalent to education in industrial mechanics/technician. The electric connection must be performed by trained and certified electrician.

### Commissioning and Maintenance

Personnel responsible for commissioning, overhaul and maintenance of the machine must be familiar with all functions, and how to operate these functions. Furthermore, they must know of all safety precautions in this manual, and which in other respects also are valid where the machine is used.

### Operation

All persons who operate and maintain the machine must be aware of the risks that may occur with its use and as described in this manual.

### Service and Repair

Responsible personnel for service and repair of the machine must have knowledge equivalent to education in industrial and design mechanics, and also know and understand the technical data of the machine described in this manual. Assisting personnel for these jobs must be trained and performed repair work must be checked by the machine owner.

## 2. Company Profile

Disperator's business idea is to provide innovative and adaptive equipment for kitchens on land as well as galleys at sea, and for the food processing industry, which enables efficient collection of comminuted food leftovers for anaerobic digestion or composting in subsequent stages, which is of benefit to society.

With over 70 years of experience in the development and production of such equipment, our devotion to this has resulted in the unique operational reliability required for the extreme conditions prevailing in the marine industry. Furthermore, our innovativeness has provided commercial kitchens on land with an alternative approach to handle food waste separation at source, complying with modern demands and being economically affordable.

Our product assortment is unique! Disperator can as the only manufacturer of such equipment offer all types of installation possibilities needed in a kitchen. Our basic range of five different series of water-based food waste disposers, consisting of three to six different sizes in each series, which may be combined with as many as 13 different mounting assemblies. Furthermore, the advantage of the basic model's design is that the waste disposers may easily be integrated into other kitchen manufacturer's mounting assembly or furniture. Thereby, each workplace in a kitchen or galley can be designed to its specific requirements regarding function, ergonomics and economy. To all this there is also the different series of water-saving processor technology for collection and storage of grinded food waste in a tank, as well as disposers that grinds food waste without any flushing water at all.

### 3. Product Description and Technical Specification

#### 3.1. Food Waste Processor 500A-GTS-E65 EXCELLENT-Series for Free-standing installation

Immediately and efficiently removing the heaviest part of kitchen waste – i.e. food leftovers - is a necessity in any commercial kitchen. In the event water-based food waste disposers connected to the municipal sewer system is not permitted in your community, a by Disperator developed unique and patent pending technology can handle the task for you. When using a GTS-Series processor, food waste can hygienically and without any heavy lifting or manual transfer easily take care of and reduce the total amount of refuse – by volume, but especially in the handling of the total weight in different transport phases!

Regardless of the selected model, the disposal procedure is the same. Food waste is fed down the inlet hopper of the machine and ground into small particles in a disposer for further transport in a pipe using a processor pump to a sealed and odorless tank. The tank is emptied by a vacuum truck approximately every four weeks or according to the driving schedule that applies in your municipality. Depending upon preference, the tank may be placed outdoors buried in the ground, as well as placed indoors. One of the unique benefits of this processor technology is that the pumping of the ground food waste can be done with minimal amount of flushing water, which gives a good operating economy as the tank does not need to be emptied as often. The slurry is transported to an anaerobic digestion facility and converted into valuable renewable energy resource (i.e. biogas), and often the digested residue can also be used as fertilizer on farmland. Biogas is one of our society's most environmentally clean and desired energy forms, as fuel for vehicles as well as to produce heat and electricity.

In its standard version the GTS-processor has a capacity of up to 15 l/min. With an average amount of food waste of 0.15 l/served meal, the processor can take care of food waste generated by as many as 4,000 served guests/hour. And this even though the storage tank, if required, can be located over 100 meters away.

To suit existing interior and logistics within the kitchen, the E65-processor outlet may be positioned either to the left or to the right of infeed opening, thus giving full flexibility in planning your kitchen and possibility to fully utilize valuable space. Disperator's broad assortment of different technical solutions for source separation of food waste can be adapted to your specific kitchen and your specific working environment, regardless of size or layout, and regardless of the specific municipal's food waste handling rules in your community!

Food waste disposers within the Disperator Excellent Series have the Declaration of Compliance issued by DNV, verifying compliance with applicable sections of MARPOL consolidated edition 2017 ANNEX V for disposal of ground food waste into the open sea.

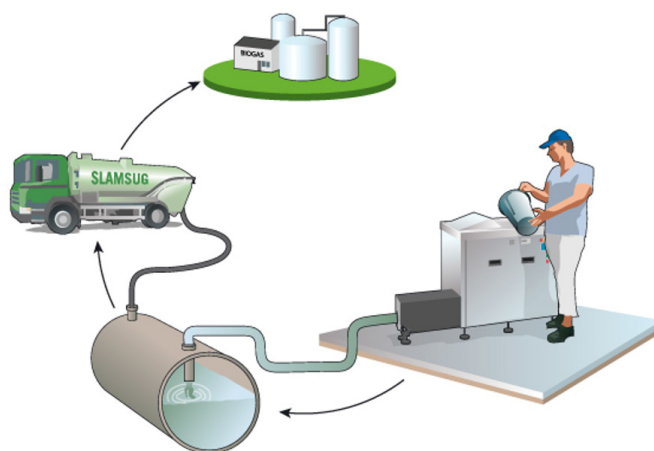

## 3.2. Technical Specification

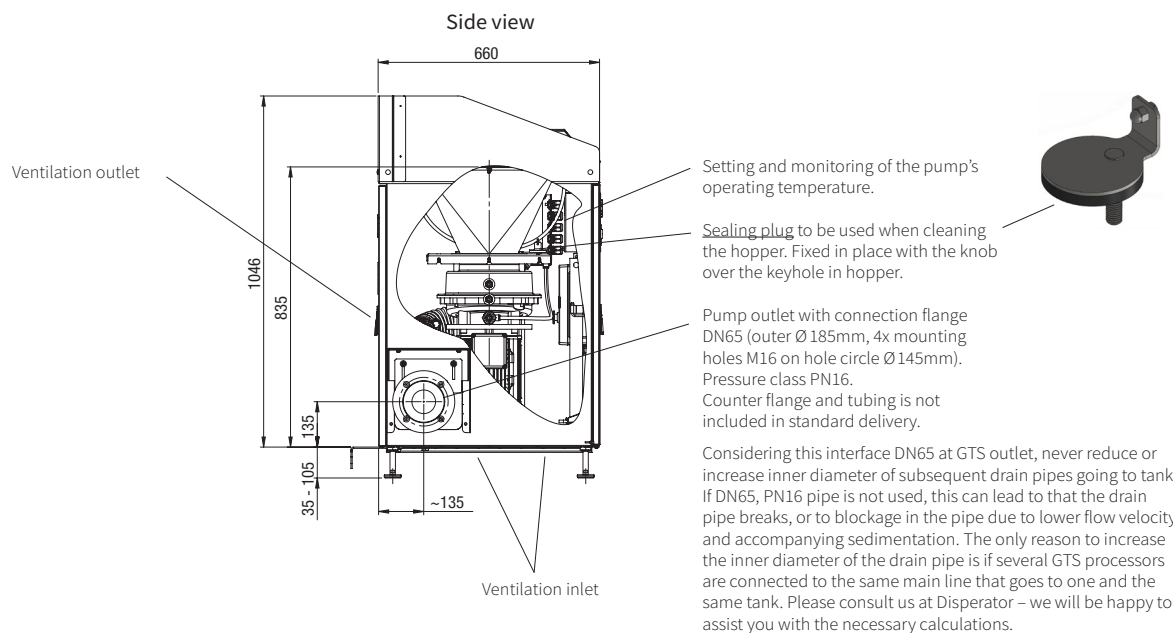
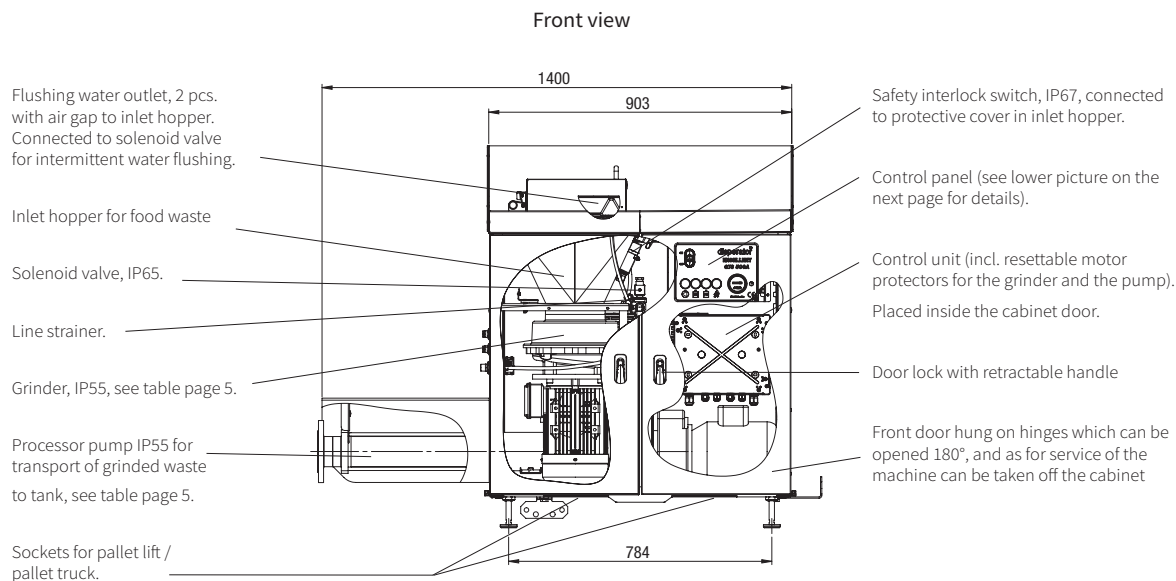

All dimensions in mm

### Top view

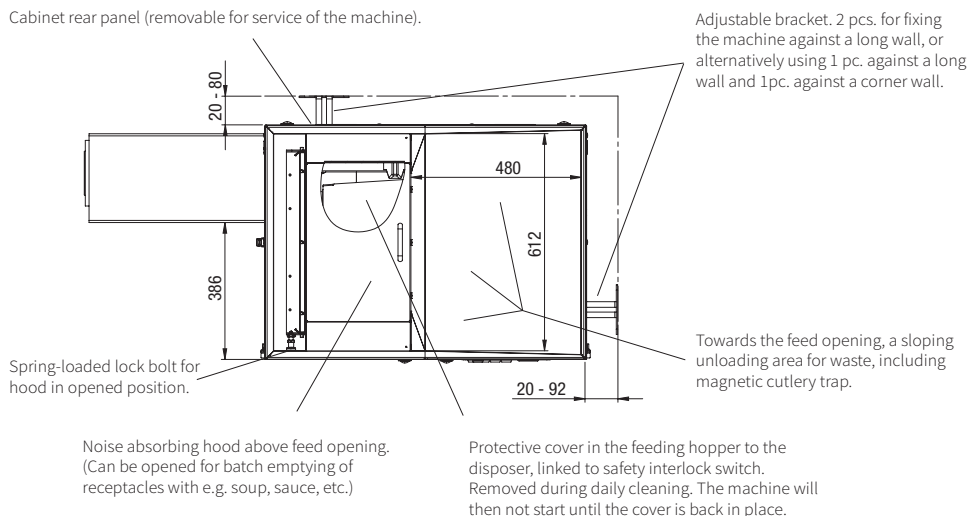

### Top view of foot

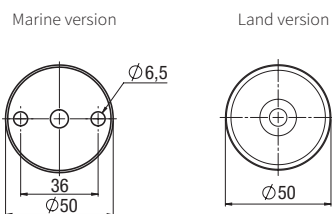

All dimensions in mm

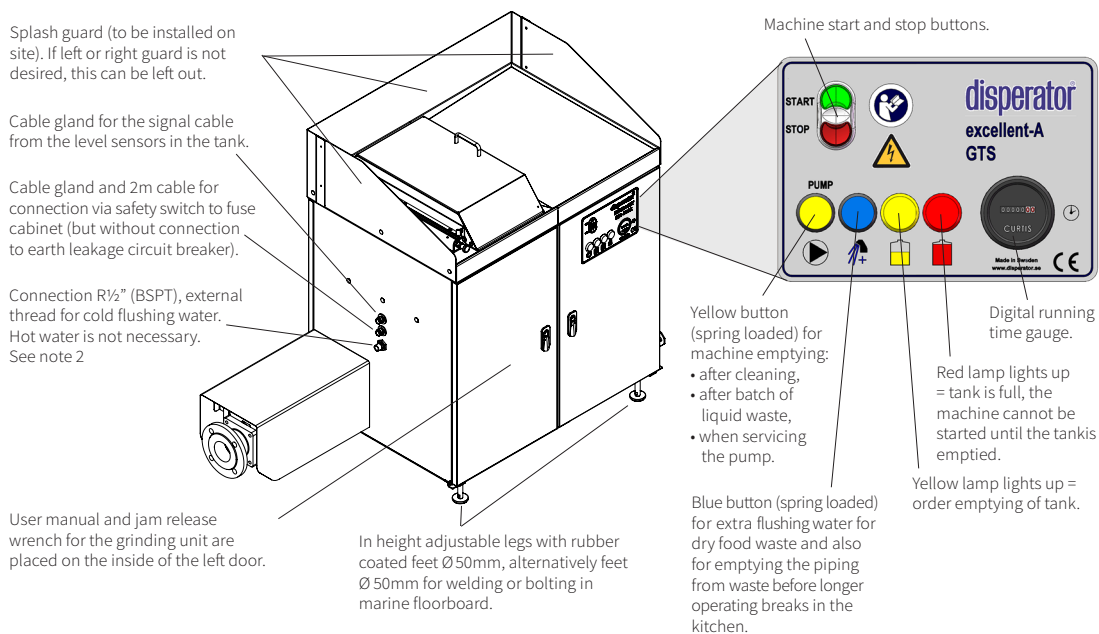

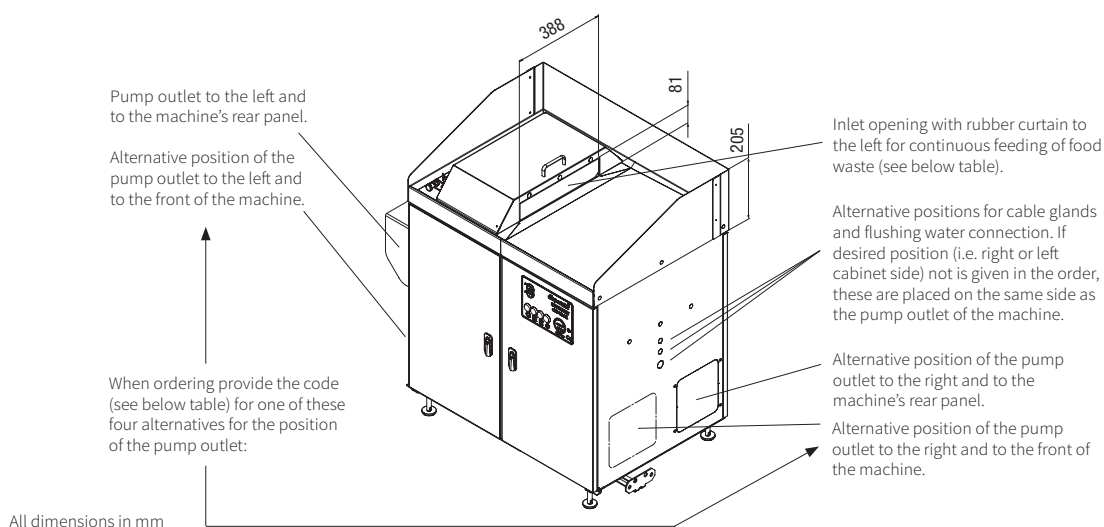

Alternative	Position of the inlet opening for waste	Position of the pump outlet	Provide the following code when ordering
1*	to the left	to the left and to the machine's rear panel	VVB
3*	to the left	to the right and to the machine's rear panel	VHB
5*	to the right	to the left and to the machine's rear panel	HVB
7*	to the right	to the right and to the machine rear panel	HHB

Technical specification	530A-GTS-E65	550A-GTS-E65	575A-GTS-E65
Standard capacity, liters/hr.	600	750	900
Optional capacity, liters/hr.	1400	1600	1800
Electrical power, kW (disposer+pump)	2,5+1,5	4,0+1,5	5,5+1,5
Rated current, A to be set on the two processor motor protectors for the following voltages:			
400V / 3 ph. / 50 Hz (disposer+pump)	9,1 (5,5+3,6)	12,2 (8,6+3,6)	15,1 (11,5+3,6)
440V / 3 ph. / 60 Hz (disposer+pump)	9,1 (5,5+3,6)	11,1 (7,5+3,6)	13,6 (10,0+3,6)
Control voltage	230V 50/60Hz	230V 50/60Hz	230V 50/60Hz
Fuse rating, slow	16A	16A	16A
Characteristic for automatic fuse	D (slow)	D (slow)	D (slow)
Net weight, kg	210	215	230
Processor drainage outlet	DN65	DN65	DN65
<i>Process pump pressure class:</i>			
*standard	PN16	PN16	PN16
*optional	PN10	PN10	PN10
The processor operates in the temperature range -5°C to +40°C			

(1) Installation material needed but not incl. in standard delivery are:

- main electrical safety switch placed on wall/bulkhead for incoming electricity, see note 1,
  - hose with protective steel-covered stocking (minimum inner -Ø 9mm) for cold flush water.
- Can be ordered from DISPERATOR.

(2) User manual with installation and service instructions, laminated operating instructions and laminated safety instructions as well as electrical documentation are included in delivery.

(3) Options:

- DN65 drain valve,
- equipment for monitoring of tank level,
- waste holding tanks for indoor installation,
- waste holding tanks for installation below ground level outdoors,
- drain pipe with pressure class PN16 in plastic or stainless steel between the processor and the tank.

Note 1: Connect the machine via safety switch to fuse cabinet, but without connection to earth leakage circuit breaker.  
Note 2: Recommended incoming water pressure 3 - 6 bar.  
Subject to any changes without prior notice.

## 4. Storage and Displacement

### 4.1. Storage of the Machine

If the machine will be stocked before installation and use the following applies:

- The machine should be stored in a dry and clean room where the relative humidity may not exceed 60%.
- Recommended storage temperature of -20 °C to + 60 °C.

### 4.2. Displacement of the Machine

The machine should not be lifted or moved by hand. During installation, we recommend using a pallet jack or forklift, and during service a lifting trolley for component parts (like the disposer placed inside the cabinet) in the machine.

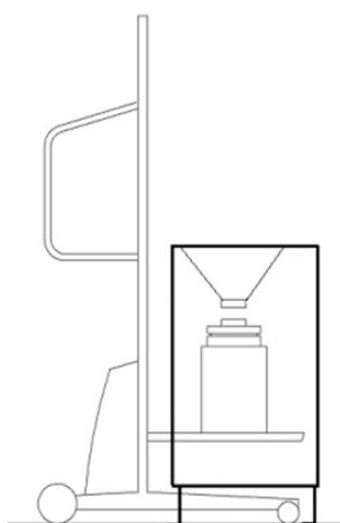

## 5. Included in Delivery

### 5.1. Documentation

- This User Manual
- Safety Instruction (laminated)
- Operating Instruction (laminated)
- The Operating and Maintenance Instruction in original for the processor pump
- Electric documentation (connection and wiring diagram, component layout diagram)

### 5.2. Food Waste Processor

<p>Food Waste Processor Inlet on 4 pcs of adjustable legs according to enclosed delivery note, including (for more detailed description see also section 3.2 in this manual):</p> <ul style="list-style-type: none"> <li>• disposer of ordered model and motor voltage,</li> <li>• pump of ordered model and motor voltage, incl. temperature monitor with display,</li> <li>• complete control system according to this manual attached electrical connection and wiring diagram, and component layout diagram, mounted in IP66 rated enclosure, including:             <ul style="list-style-type: none"> <li>• contactor for disposer and pump with resettable motor protection, zero-voltage release and operating coil,</li> <li>• controls with pushbuttons and indicator lights,</li> <li>• running time gauge,</li> <li>• solenoid valve and line strainer, G½",</li> <li>• safety interlock switch.</li> </ul> </li> </ul>	
<p>Splash guard, 1 pc. for "on-site assembly" on the inlet bench as shown on the above photo, and also in section 3.2.</p>	
<p>Bracket, 2 pcs. for fixing the machine against long wall (or corner wall) as shown in section 3.2.</p>	
<p>Jam release wrench, 1 pc. for release of disposer grinding unit, if a non-grindable object by mistake happens to fall therein. Is placed in the holder on the left-hand door inside the cabinet.</p>	

## 6. Installation Description for the Machine

### 6.1. Assembly of the Machine

#### 6.1.1. Deployment of the Machine

Unless otherwise requested in your order, the machine comes with its legs on a pallet. To minimize the risk of injury, at least two persons must be present when the machine is deployed. The machine has a net weight as per section 3.2 above, so the lifting equipment (e.g. forklift and pallet jack) to be used must be checked to withstand this weight.

Lift the machine from the pallet at the socket positions in the cabinet bottom plate shown in the "Front view" in section 3.2 in this manual. Then move the machine to the designated place of installation.

Before the machine is set down on the floor, adjust the four legs so that the desired machine height is obtained. After the machine has been placed on the floor, check with a spirit level that it is horizontal, and adjust the legs if necessary.

#### 6.1.2. Fixation of the Machine

The machine must be fixed to the wall/bulkhead or floor/floor plate. When stopping quickly (e.g. if cutlery mistakenly jams the grinding unit) the torque of the disposer motor will cause the machine to turn. This can give undesirable forces on the pump's connection to the drain pipe that goes to the tank (see paragraph 6.3 below), which can cause leakage. To prevent this, two adjustable brackets are included in the delivery for fixing the machine against a long wall or alternatively using 1 pc. against long wall and 1 pc. against corner wall. See section 3.2 ("Top view") and section 5.2 above.

The pump must be anchored on the outlet side before start-up. This is to avoid the pump rotating around the stator pack and thus damaging the stator.

For marine installation the machine is instead fixed by means of e.g. plates which are welded to the floor plate, whereupon the machine legs are placed and screwed onto these plates as shown below.

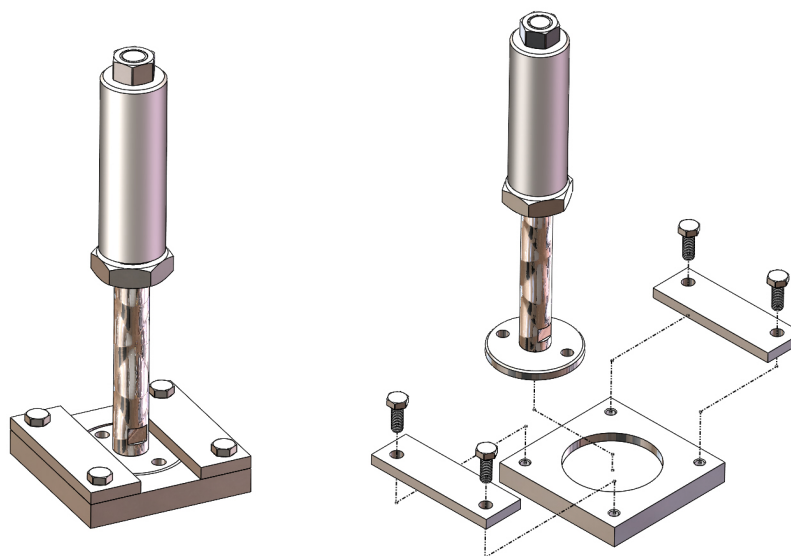

#### 6.1.3. Mounting of the Splash Guard

The delivered splash guard (see section 5.2 above) to be mounted against the outer edge of the cabinet top plate in such a way that one side of the cover is placed on back of the cabinet. Depending on the wishes of the kitchen, one or both short sides of the machine may also be equipped with splash guard. See section 3.2 above. Fix the delivered splash guard by screwing into the ready made holes in the outer edge of the cabinet top plate. After the splash guard has been fixed by screwing into these holes, seal off the gap between the top plate and splash guard with rubber sealant (silicone).

## 6.2. Flushing Water

For the machines ordered for connection to flushing water according to the requirements of standard EN 1717 (in the UK also WRAS), or to be installed in countries where this standard must be complied with, the machine's draft flushing water is delivered according to these requirements to prevent contamination by suction in drinking water pipes.

This standard EN 1717 defines five liquid categories that are or could come into contact with drinking water. Category 5 is the category with the highest protective requirements and which applies in all kitchens where food is handled, regardless of whether food waste management equipment is there or not. If stated when ordering, all Disperator's machine models can be delivered in accordance with the requirements for category 5, ie. the category with the highest protection against contamination of drinking water pipes.

Connection of flushing water to the delivered machine may only be carried out by a qualified VA installer and in accordance with current local VA regulations. DISPERATOR takes no responsibility for, according to standard EN 1717, a machine that is incorrectly connected to the drinking water line.

The machine's automatic rinsing water control is to be connected to cold rinsing water (hot water is not needed).

### 6.2.1. Water Pipe DN15

To provide the correct amount of flushing water to the machine, the incoming water pipe (incl. accessories and protection devices against suction, cut-off valves, etc.) must have the same dimension as the connection to the machine assembly, ie. DN15. No throttling may exist up to the flushing water connection on the machine.

### 6.2.2. Line Strainer DN15 and Solenoid Valve DN15

The delivered line strainer, DN15 must be mounted in the flow direction before the solenoid valve, DN15 in the incoming cold water pipe to the machine. Also make sure that the line strainer and solenoid valve are mounted in the correct flow direction (see the arrow on these components), and that the nut on the line strainer (which is to be opened when cleaning the line strainer) is directed downwards. Line strainer and solenoid valve have G½" (BSPP), internal thread.

For funnel mounting that is welded into other manufacturers' table tops / workbenches, and for freestanding cabinet and table mounting, these components are pre-assembled from the factory on the assembly for connection to cold water supply. Connection to these assemblies is R½" (BSPT), external thread.

### 6.2.3. Hose with Protective Steel-Covered Stocking for Flushing Water, minimum Inner-Ø 9mm

Between the incoming water pipe mounted on the wall/bulkhead, and the connection for flushing water on the machine assembly, a hose with protective steel-covered stocking (with minimum inner-Ø 9 mm) must be fitted. This hose absorbs the compressive push in the pipe when the flushing water is turned on and absorbs any small vibrations which may occur during the grinding process of the disposer. This hose is not included in standard delivery but is available as an option from Disperator.

### 6.3. Connection of Pump Outlet to Drain Waste Pipe going to Tank

The drain waste pipe installation going to tank for the delivered machine must only be made by an authorised installer of sewer supply for pressurized pipes and in accordance to valid local regulations.

#### 6.3.1. To Check before the Connection is made

Check with the installer of the drain waste pipe going to tank to confirm that:

- hose, tubing, fittings and any valves used have the pressure class PN16,
- pipe draw to tank outside building has been done in the ground on a frost-free depth, or otherwise protected against freezing,
- monitoring of the tank level exists, which also stops the machine when the tank is full,
- the tank is ventilated,
- frost-free flushing water outlet with hose and gun are available when emptying the tank.

#### 6.3.2. Specification and Connection of Drain Waste Pipe

Use a movable flange with gasket on the drain line when this is connected to the machine's pump outlet DN65 (outer  $\varnothing$ 187 mm, 4x mounting holes  $\varnothing$ 18 mm on hole circle  $\varnothing$ 145 mm).

Never reduce or increase the inner diameter of the drainpipe that goes to tank. If DN65, PN16 pipe is not used, this can cause the drainage pipe to break, or alternatively there will be a stop in the pipe. The reasons for this are that if the GTS-processor is connected to a drainpipe with:

\* **less diameter than the pump outlet**, the internal resistance of the drainpipe will increase exponentially, which can cause the pump and / or pipe to break apart.

\* **larger diameter than the pump outlet**, the flow rate in the drain pipe is lowered, and the food waste therefore settles more easily (i.e. lays more easily on the bottom of the pipe), and to a greater extent only the liquid phase moves to the tank. Over time, this can lead to blockage in the pipe.

The only reason to increase the inner diameter of the drainpipe is if several GTS-processors are connected to the same main line that goes to one and the same tank.

Consult us at Disperator - we will be happy to assist you with the necessary calculations to obtain a reliable facility.

## 6.4. Electrical Connection

The electrical connection of the delivered machine must be done by an authorized electrician and in accordance with valid local regulations.

The wiring made at the factory, and the electrical connections to be done during installation, are shown in the electrical diagram attached to this manual. The machine's specific electrical data is given in this manual, section 3.2, as well as on its serial number plate located on its outer cover (in cabinet assemblies there is also an additional plate inside the cabinet).



Also note that the electrical connection of level sensors at the tank, as well as their connection to the GTS-processor in the kitchen, as shown in the enclosed electrical diagram, applies to the level sensors of Disperator's manufacture according to section 7 below. For other makes and solutions of level sensors, please contact Disperator or your dealer.

### 6.4.1. Supply Voltage

Check that the supply voltage to be connected corresponds to the specified voltage on the machine's serial number plate.

### 6.4.2. Mains Fuses

Check that the supply voltage for the delivered machine is fused and protected as specified in section 3.2 of this manual.

### 6.4.3. Wall/Bulkhead Mounted Electrical Security Breaker

A separate wall / bulkhead mounted main electrical security breaker (circuit breaker) must be connected in the incoming power line to the machine. The electrical security breaker is not included in standard delivery but is available as an option from Disperator.

### 6.4.4. Cable Dimension

Use connection cable having 1.5 mm<sup>2</sup> wires for machines having a rated current up to 14A. For machines having a rated current above 14A, use 2.5 mm<sup>2</sup> wires. The rated voltage and current is specified on the machine's serial number plate.

### 6.4.5. Cable Protection

All electrical cables must be protected against damage by being securely fastened, for example to kitchen furniture or wall/bulkhead. If there is a risk that the cables can be damaged, for example by passing trolleys, then the cables must be protected by a flexible sleeve or conduit. The cables must never be kept on the floor/floor plate.



### 6.4.6. Earth Wire

- a) The earth wire must be longer than the main voltage wires, when connecting to the cable terminal block. This gives earth protection in case the voltage wires become unfixed in the cable nipple, allowing them to be pulled from their terminals.
- b) The machine must not be connected via residual current device, RCD (also called earth leakage circuit breaker). The reason is that the currents in all 3-phase motors during start-up are out of balance until the motor comes up to speed, why the RCD without intended reason will trip. Note also that when the machine's electrical connection is permanently installed through a wall / bulkhead mounted electrical security breaker (see item 6.4.3. above), usually under current rules in most countries no RCD is required.



#### 6.4.7. Direction of Rotation for the Disposer and the Pump

- a) The disposer operates correctly irrespective of the motor's rotational direction. It is therefore irrelevant in which sequence the electrical phases are connected to the disposer motor.

##### IMPORTANT

- b) However, the correct function of the GTS-processor pump is dependent on the pump rotating in the correct direction, which is shown by an arrow on the serial number plate. In other words seen from the pump motor drive side, its axis with the rotor shall rotate counterclockwise. Check the pump rotation by only for a short moment start the GTS-processor. If the shaft of the rotor does not rotate counterclockwise, change the sequence of the connection of the pump motor's three phases.



Checking that the pump has the correct direction of rotation can also be done by starting the GTS processor for a short moment, while holding the handset for the machine's outlet. If there is an overpressure (ie "pump blows out") at the outlet, the pump will rotate properly. If there is a negative pressure (ie "the pump sucks"), the electrical phases must be switched over.

#### 6.4.8. Protective Cover Connected to Safety Interlock Switch

- a) Check the function of the safety interlock switch. The machine and its motor idling speed must stop before the protective cover above disposer inlet has been released and removed.
- b) If necessary, fine-tune the positioning of this switch and make sure it is properly fixed.
- c) Ensure that the key mounted on the protective cover can easily move in and out of this switch.
- d) Also make sure that the important mechanical seal around this key is in place and in good condition.



#### 6.4.9. Sensor for Monitoring Pump Temperature

The sensor for monitoring the pump operating temperature, is placed in the pump stator, and are ready connected from the factory. The pump's operating temperature as given from this sensor is shown on the display located in the enclosure placed on the inside of the cabinet's right-hand door. For more information, see section 6.5.4. below, and if necessary, Chapter 13 of the pump's operating and maintenance instructions in original as enclosed.

## 6.5. Start Up and Final Testing

Fasten the laminated operating and safety instructions (included in delivery) in a place on the wall / bulkhead where they are easily seen by the operator before the start of the machine.



### 6.5.1. Check before Start Up

Disconnect the power on the main electrical security breaker (placed on the wall/bulkhead) and lock it with a padlock if you need to leave the machine before this section 6.5 is completed.

Check that the rotary shredder in the inlet opening of the disposer turns freely 360° in both directions by hand, and make sure that no foreign object has been dropped into the grinding unit during installation.

### 6.5.2. Important Preparations before Starting-up the Machine

In case there is a shut-off valve in the machine's outlet pipe (drainpipe), this valve must be opened before starting the machine. The pump of the machine must never run against a closed valve.

Pour a bucket of water mixed with 1 dl of hand dishwashing detergent into the inlet opening of the machine. This liquid mixture will give the pump the necessary lubrication during start up. The pump should never run dry.

### 6.5.3. Checks during Start-up

- a) Start the GTS-processor and determine that the grinder and pump rotate. For correct function anti-clockwise rotation of the pump is a must (see item 6.4.7.b above).
- b) Check for automatic flushing water pulse at predetermined intervals (from factory recommended and adjusted to every 15 sec). The first water pulse should come directly when starting the machine.
- c) Also check that extra flushing water flows when pushing blue springback push button.
- d) When the yellow springback push button is pressed, check that only the pump is running and that it then empties the inlet hopper on liquid into the drain line.
- e) Check assembly, flushing water connections and drain connections for possible leaks.
- f) Make sure that the safety interlock switch works properly according to section 6.4.8 above.

### 6.5.4. Setting the Monitoring of the Pump's Temperature

See section 6.4.9. above. The display for the monitoring of the pump's operating temperature is in the enclosure placed on the inside of the cabinet's right-hand door, and managed as follows:

#### Netzsch – control unit

- a) If no key is pressed, the measured operating temperature in the pump stator is given on the display.
- b) Press the SET-key, and the pump switch-off temperature is indicated.
- c) Press the SET-key and simultaneously the up arrow-key ↑, or the down arrow-key ↓, and the pump switch-off temperature is increased or decreased. Release the arrow-key before releasing the SET-key, and the new set temperature will be stored.
- d) Check the function of the temperature guard for the pump stator by adjusting the display to the room temperature where the machine is installed. Restart the machine. If the temperature guard is operating as required, the machine after a while shall stop.
- e) For the machine to operate without stop also when processing hot food waste, it is recommended that the monitor is adjusted to a switch-off temperature of +50°C. The monitor may never be adjusted to a higher value than +69°C switch-off temperature.
- f) If the switch-off temperature is exceeded, or power failure or short circuit occurs, the machine is turned off, and the display will flash while a buzzer will sound. The flash and summer signals are switched off by pressing the down arrow-key ↓.
- g) Sensor failure code is stored and shown on the display also after the defect has been corrected and is erased by pressing the down arrow-key ↓.

**Jumo B70 – control unit**

- a) If no key is pressed, the measured operating temperature in the pump stator is given on the display.
- b) When the P button is pressed, and the pump switch-off temperature is indicated.
- c) To raise or lower the pump switch-off temperature, press the P button and set the temperature using the up ↑ or down arrow ↓ button. Finish by pressing the P button and the new temperature setting is saved.
- d) Check the function of the temperature guard for the pump stator by adjusting the display to the room temperature where the machine is installed. Restart the machine. If the temperature guard is operating as required, the machine after a while shall stop.
- e) For the machine to operate without stop also when processing hot food waste, it is recommended that the monitor is adjusted to a switch-off temperature of +50°C. The monitor may never be adjusted to a higher value than +69°C switch-off temperature.
- f) If the shutdown temperature is exceeded, or a power failure or short circuit occurs, the machine shuts down and K1 on the display goes out.

**Jumo T100 – control unit**

- a) If no key is pressed, the measured operating temperature in the pump stator is given on the display.
- b) To raise or lower the pump switch-off temperature, use the up ↑ or down arrow ↓ button to scroll to desired value. Press the OK button and the new temperature setting is saved.
- c) Check the function of the temperature guard for the pump stator by adjusting the display to the room temperature where the machine is installed. Restart the machine. If the temperature guard is operating as required, the machine after a while shall stop.
- d) For the machine to operate without stop also when processing hot food waste, it is recommended that the monitor is adjusted to a switch-off temperature of +50°C. The monitor may never be adjusted to a higher value than +69°C switch-off temperature.
- e) If the switch-off temperature is exceeded, or power failure or short circuit occurs, the machine is turned off, and a failure code is shown in the display.

**6.5.5. Final Measures**

If the machine fails to operate, see section 9.3. "Trouble shooting" in this manual.

Before the documentation and the jam release wrench for the disposer grinding unit are handed over to the personnel responsible for the machine in the kitchen/galley, instruct this personnel about the operation and daily maintenance of the machine, especially about what is said under section 8 and 9 of this manual.



## 7. Installation Instructions for Level Sensors and Overfill Protection in the Tank

Disperator's design of level control and overflow protection for grinded food waste in the tank is not included in the standard delivery of the machine itself. This is an option because our customers sometimes use other makes of level sensors to Disperator's food waste disposers and processors. This happens for example when the competitor's food waste disposers are replaced with equipment from Disperator, but competitor's tanks and level sensors operate and can be used with the new machine from Disperator. If necessary, please contact Disperator for advice and discussion on these issues.

Disperator's equipment for control of tank levels and controlling the machine in the kitchen has long been well-tested and proven reliable. It consists of two floats mounted in two brackets of different length. The length of each bracket is determined from the kitchen's request for the alarm levels that will apply and will be calculated as shown in the example on the next three pages. The float brackets are fixed in the tank at an appropriate and for the floats undisturbed place, and where it is also possible to access them if future service needs arise.



Suitable mounting length of free cable is 15cm outside the float bracket.

Finally, the two floats are connected to the cable that is pulled in the prepared protective tube (minimum  $\varnothing 16$  mm) to the machine in the kitchen. Often, this protective tube follows the same path as the machine sewer pipe, and is also to be fixed to this pipe. To this user manual attached electric diagram is for a GTS-food waste processor with Disperator level sensors in the waste tank, and shows the electrical connection at the tank as well as the connection to the GTS-processor in the kitchen. For other makes and solutions of level sensors in the waste tank please contact Disperator or your dealer.

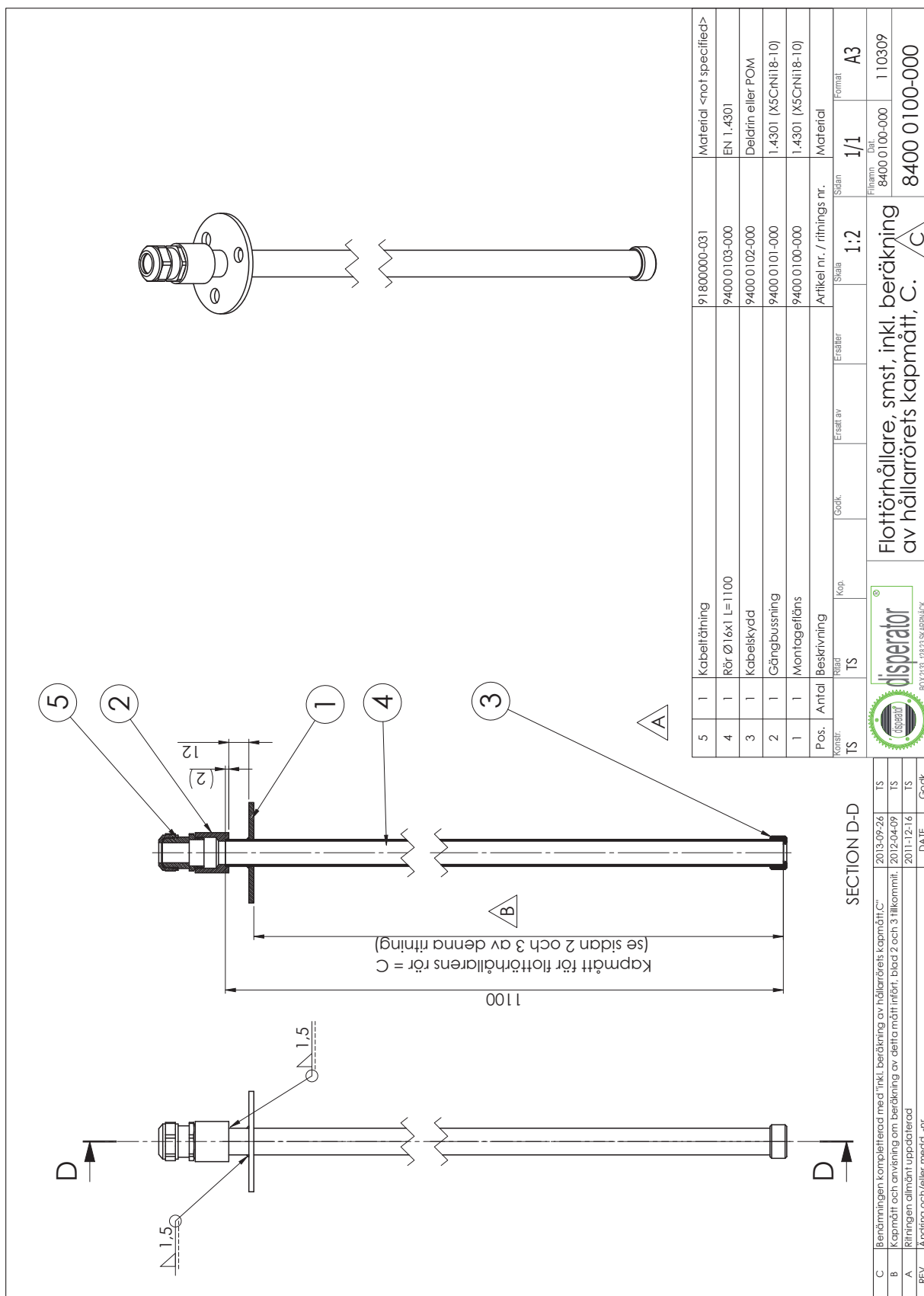

This document is our property and shall not be used for manufacturing or communicated to any other person or company.

Flottör med hållare för 70% fyllnadsgrad av tank.

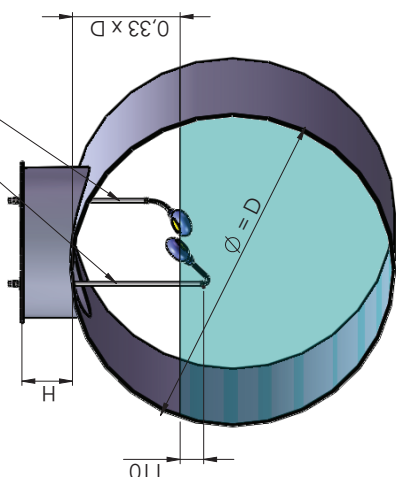

Tank fylld till 70%

## Beräkning av hållarrörets kapmått, C.

D = tankens innerdiameter, mm.

H = manluckans höjd (inkl. lockets fjocklek), mm.

$C_{70}$  = flottörhållarens längd, mm, för 70% fyllnadsgrad av tank =  $0,33 \times D + H + 110$ .

$C_{90}$  = flottörhållarens längd, mm, för 90% fyllnadsgrad av tank =  $0,16 \times D + H + 110$ .

För beräkningsexempel av  $C_{70}$  och  $C_{90}$ , se sidan 3 av denna ritning.

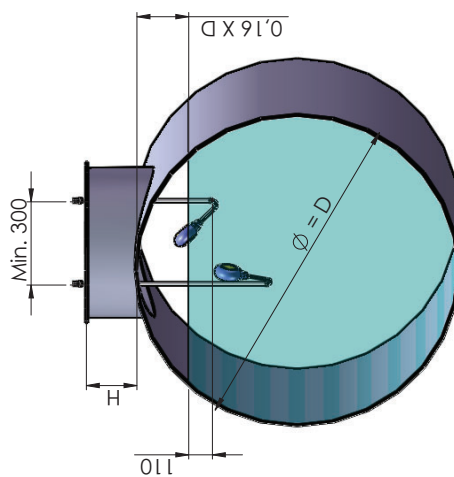

Tank fylld till 90%

Not 1: Minimivstånd mellan flottörhållarna = 300 mm.

Not 2: Fri kabelängd mellan hållarrörets ände och kabelingång i flottör ska vara 150 mm.

Not 3: För att undvika att flottör krockar med tankens innervägg måste tankens innerdiameter vara minst 900 mm.

This document is our property and shall not without our permission be altered, copied, used for manufacturing or communicated to any other person or company.

Den här tekniska teckningen gäller enligt SS-ISO 2768-X. Skapa kopian i 3D. Inneboende X mm. Generell yttillämpning, Ra X.

Konstr.	Risid	Dat.	Gråk.	Dat.	Vat	Sida	Rev
TS	TS	120409			Aspjarl Flottör	2/3	A3
		Beskrivning			8400 0100-000		
		Flottörhållare, smst, inkl. beräkning av hållarrörets kapmått, C.			8400 0100-000		
		Mälardvägen 9, 14171 Segeltorp			Revision		
					8400 0100-000		C

Exempel på för litet tanktvärsnitt för att använda denna utrustning för nivåkontroll, då flottörerna kan störas varandra och kollidera med tankens vägg.

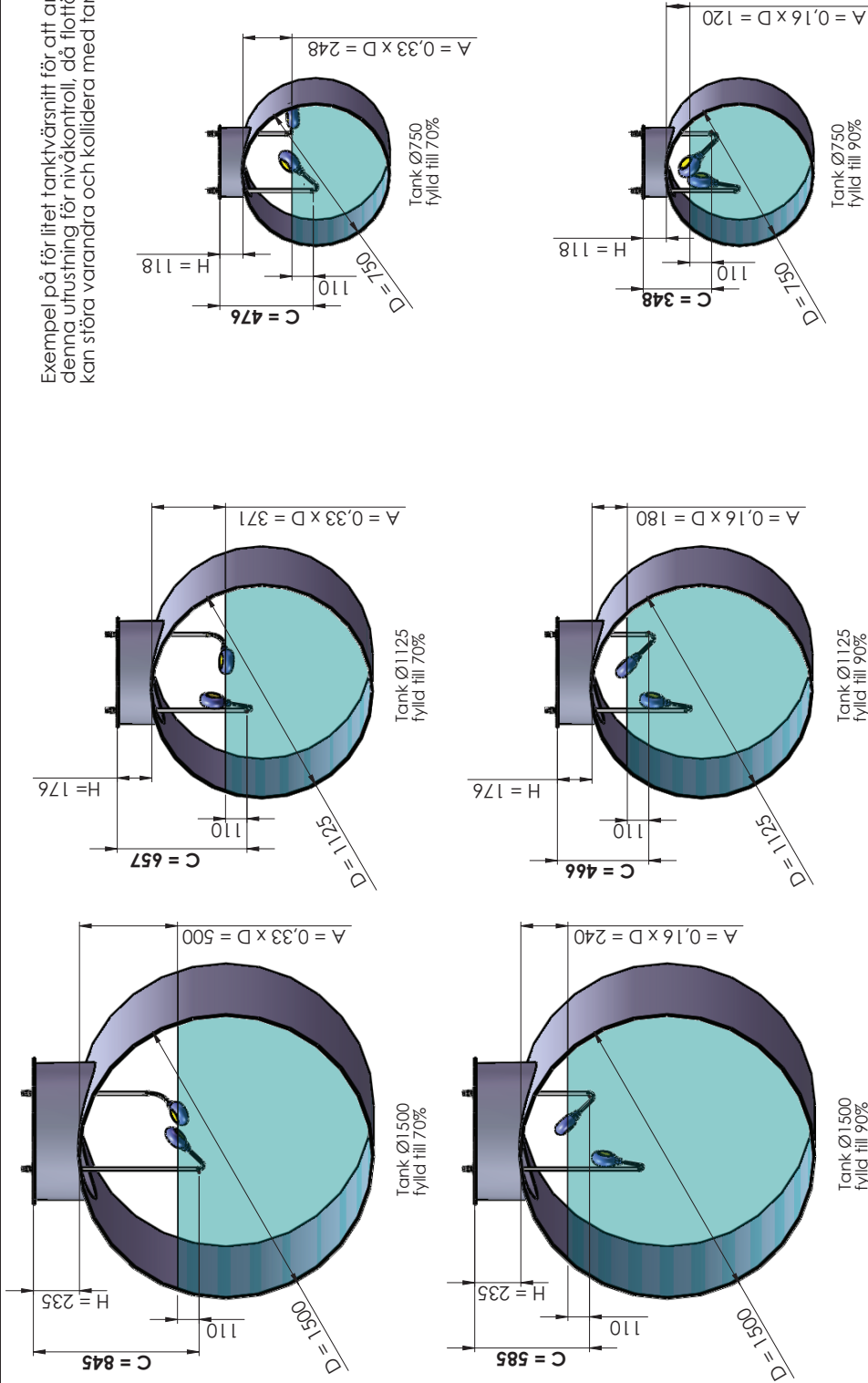

### Flottörrörets längd - resultatexempel.

- D = tankens innerdiameter, mm.
- H = manluckans höjd (inkl. lockets tjocklek), mm.
- $C_{70}$  = flottörrörets längd, mm, för 70% fyllnadsgrad av tank =  $0,33 \times D + H + 110$ .
- $C_{90}$  = flottörrörets längd, mm, för 90% fyllnadsgrad av tank =  $0,16 \times D + H + 110$ .

Konstr.	TS	Risö	TS	Dat.	120409	Godk.		Dat.		Vikt		Rev. A.3
Beskrivning	Flottörrörelse, smst, inkl. C											
Asy/Pat/Finans	8400 0100-000											
Ritningsnummer	8400 0100-000											
Revision	C											



This document is our property and shall not without our permission be copied, reproduced, or otherwise disseminated to any other person or company.

Där toleranser ej anges gäller Skrapa kärnet bulning SS-ISO 2768-X Innebörskrädie X mm Generell yttre mått. Ra X

## 8. Safety Instructions

### Read these safety instructions before using the machine!

1.



- 1.1 For continuously fed machine with open inlet for food waste
- There is a rotating disc under the machine inlet for food waste. Do not insert hand into this inlet when the machine is running.
  - Use protective goggles when bones and similar types of hard food waste are fed into the machine.

- 1.2 For batch fed machines with tightly sealed top cover above the inlet for food waste.  
There is a rotating disc under the machine top cover. Do not open this protective cover when the machine is running.

2. If the machine is running even though the interlock (protective cover) above the machine inlet is open, press the red stop button, disconnect and lock the main electrical safety breaker on the wall/bulkhead with a padlock, and call for service.



3.

During all overhaul and service work on the machine, the main electrical safety breaker on the wall/bulkhead must be locked in the OFF-position with a padlock.

4.



Depending on how the machine is assembled to the surrounding kitchen/galley furniture, it may emit a noise level of more than 70dB(A). Use hearing protection when bones and similar types of hard food waste are fed into the machine.

5.



Immediately press the red stop button if e.g. cutlery or other non-grindable items are found in the food waste or accidentally are dropped into the machine, or if unfamiliar noises are heard. See section 8.3, "Trouble shooting" in the user manual.

## 9. Operating Instructions

**The machine is intended for collection of food waste only!**  
**Also note the following:**

1. Food waste that is difficult to grind, such as vegetables with long fibers, tough fish skins and sinewy meat, should when being fed into the machine be divided into pieces of 3-5 cm (1-2 inch) and mixed with other food waste.



2. Dry and sticky food waste (such as steamed rice, pasta, mashed potatoes, bread) should soak in water before being fed into the machine.



For processors in the GTS-series, extra flushing water can if needed also be added by pressing the blue button.

3. Hard shells in various forms (e.g. from clams, oysters, crabs etc.) must not be fed into the machine as it among other things causes drainpipe blockages.



Also larger amounts of eggshells must not be fed into the machine as it also causes drainpipe blockages.



- 4.1 For continuously fed machines with open inlet for food waste and having a motor power of 2.5kW or more, also larger amounts of bones, and larger sized bones, can be mixed with other food waste when being fed into the machine.



- 4.2 For batch fed machines of 2.5kW or more, and with tightly sealed top cover above the inlet for food waste, also any single larger sized bone can be mixed with other food waste when being fed into the machine.

## 9.1. Start and stop



If yellow lamp lights up - order emptying of tank	If red lamp lights up - the machine cannot be started until the full tank has been emptied
---	--

1. Press green button (1) – machine with intermittent flushing water starts and runs for 2 minutes
2. Feed food waste into machine in an even and continuous manner
3. Press red stop button (0) – machine stops before the automatic stop
4. Press and hold yellow spring-back button for emptying the machine:  
\* after cleaning  
\* after feeding of liquid waste
5. Press and hold blue spring back button for extra supply of flushing water for dry food waste

## 9.2. Daily cleaning of the disposer

1. Press green button (1) – machine and intermittent flushing water starts. Flush clean the food waste unloading area. Open the hood and flush clean in the inlet feeding hopper
2. Press the red stop button (0) – the machine stops
3. Use main electrical safety breaker placed on the wall to disconnect electrical supply. Lock the breaker with a padlock if you temporarily need to leave the machine before cleaning is complete according to step 8 below
4. Use protective gloves
5. Remove the protective cover in the inlet hopper above the grinder inlet by loosening the black star knob on the outside of the hopper, inside the cabinet. **Important** – with the same knob instead screw on the sealing plug which looks like this.....

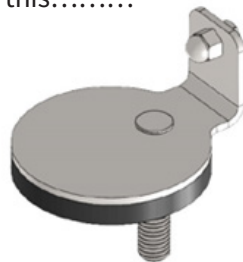

..... and which hangs on a string in the cabinet. From the outside of the cabinet the plug shall cover the two holes in the hopper.

6. Clean the inside of the hopper (especially careful below the cabinet's top plate), and also the underside of the protective cover. If needed use a mild detergent

7. Check that the seal around the key on the cover is in place and is in good condition. If necessary, replace the seal

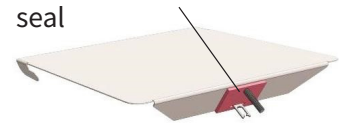

8. Remove the sealing plug (see picture in step 5) and reattach the protective cover into the hopper. Then the key slides into the safety interlock switch which connects. Close the hood above the inlet hopper
9. Connect the electrical supply on the main electrical safety breaker placed on the wall
10. Press the green button (1) to start and empty the machine from waste and water
11. Press the red stop button (0) – the machine stops

### Machine Downtime for more than 5 days

Empty the outlet drain pipe from waste by simultaneously pressing the yellow and blue buttons, and let the pump run with continuous water flushing for approx.

10 000 per running meter

## 9.3. Trouble Shooting

### 9.3.1. Disposer Reduces Speed, Stops or does not Start

#### A humming sound might be heard from the disposer motor

1. Press the red stop button (0).
2. Use the main electrical safety breaker placed on the wall to disconnect electrical supply. Lock the breaker with a padlock or a cable tie if you temporarily need to leave the machine before step 11 below is completed.
3. Use protective gloves. Remove the protective cover above the disposer inlet by unscrewing the star knob on the outside of the hopper, inside the cabinet. Check if something is jammed in the disposer grinding unit.
4. If something is jammed, place the jam release wrench on the center washer. The recess on the lower plate of the wrench should grab one of the two bars on the disc, see picture below.

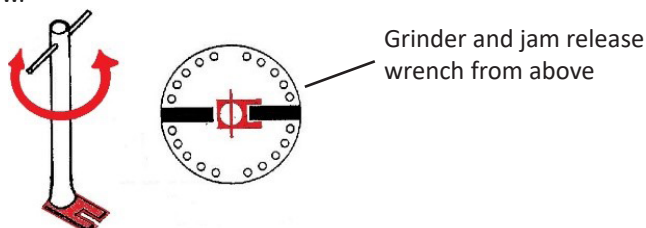

5. Release the grinder by rotating the wrench backwards and forwards until the shredder rotates freely a complete turn in both directions. If needed, extend the bar on the wrench and hit the bar with a hammer.
6. Remove the jam release wrench.
7. Remove any non grindable object from the disposer, e.g. cutlery.
8. Remount the protective cover and fix it with the star knob. Make sure that the key on the cover slides into the interlock switch that closes it.
9. Check wall fuses / automatic breakers. Change/reset if needed.
10. Reset motor protectors by pressing in the two red buttons on the terminal box AS1 inside the cabinet.
11. Connect the electrical supply on the main electrical safety breaker placed on the wall.
12. Press the green button (1) to start and empty the machine.
13. Press the red button (0) - the machine stops.



### 9.3.2. Machine Starts but there is no Flushing Water

1. Is the shut off valve in the water supply pipe open? If not, open this valve.
2. Is a clicking sound heard when activating the solenoid valve (starting the machine)? If not, change the coil.
3. Is the line strainer clogged? Turn off water supply, open nut on strainer and clean. Close nut on strainer carefully without damaging the seal, and make sure it is tight when the machine is restarted.

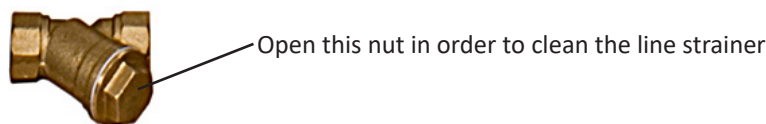

4. Have timer relay settings been changed by mistake, or is timer out of order?

### 9.3.3. Machine does not Start and makes no Sound

1. Check that the protective cover in the inlet hopper is in place and properly closed.
2. Check that the main electrical safety breaker is in ON-position.
3. Make sure the wall fuses / automatic breakers are switched on.
4. Check that the two motor protectors for disposer and pump are reset by pressing in the two red buttons on the terminal box AS1 inside the cabinet.

**If the fault cannot be remedied, please contact authorized service personnel or Disperator AB / local representative. Always provide the disposer's serial number when contacting Disperator.**

## 10. Service Instructions

### 10.1. Authorization

Disconnection and reconnection of the machine to incoming water & sewer service and electricity may only be carried out by authorized personnel and in accordance with valid local regulations.

Upon delivery of the machine, its electrical documentation is attached to this user manual.



10.2. Exploded View and Spare Parts List for the Disposer

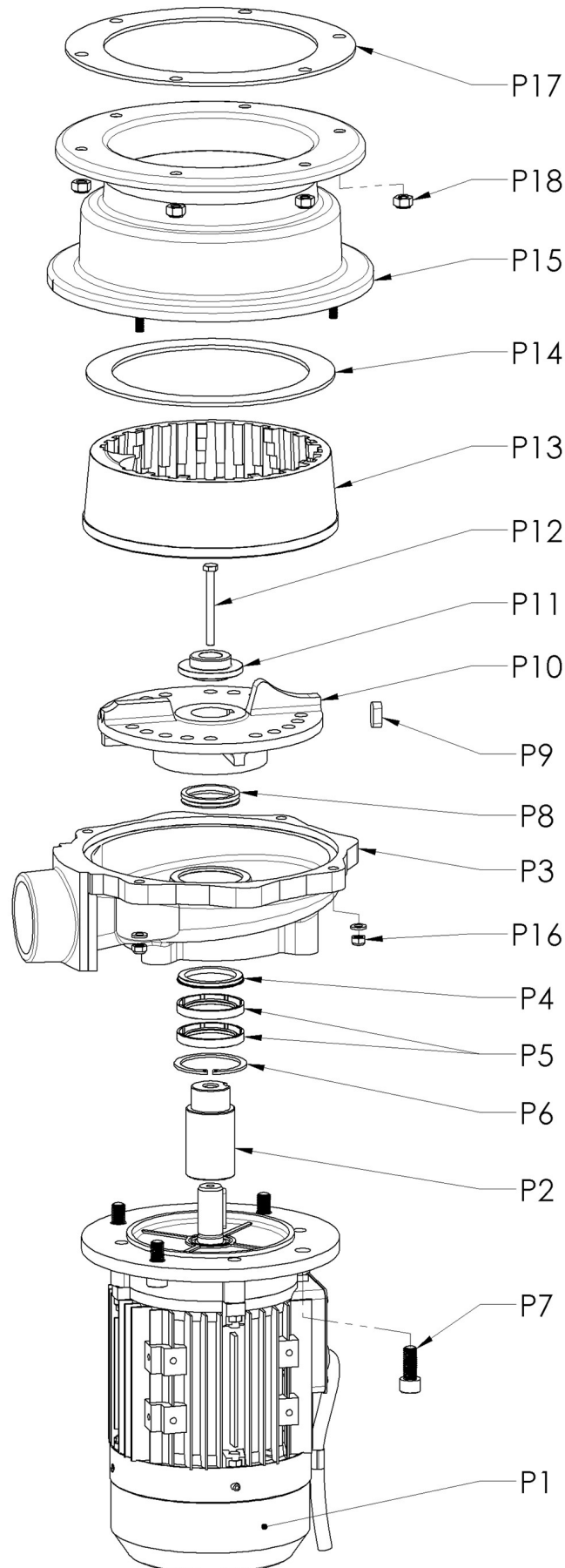

**SERVICE PACKAGE 1 - Parts to be replaced during disassembly and for general inspection**

The parts in service package 1 are not sold separately

Position No:	Qty:	Denomination:	Spare Part No:
P4	1	Washer for V-ring seal	-03/00
P5	2	Axle seal, with stainless spring	-03/02
P6	1	Locking ring	-03/03
P7	4	Screw for end shield assembly	-23
P8	1	V-ring seal	-03/01
P9	1	Key for carrier	-10
P12	1	Axle screw	-07
P14	1	Seal for stationary shredder	-05
P16	4	Locking nut and washer for hood assembly	-25
P17	1	Seal for hood flange	-08
P18	6	Nut for disposer assembly	-22
<b>Not depicted parts</b>			
P19	1	Special grease for seals and carrier	-04
P20	1	Rubber sealing compound	-09
<b>Parts depicted on the next page</b>			
P32	1	Seal for Safety Interlock Switch	-39/01
P34	1	Seal for plug used when cleaning the inlet feeding hopper	-67

**SERVICE PACKAGE 2 - Parts that together with parts in SERVICE PACKAGE 1 must be replaced due to wear**

Position No:	Qty:	Denomination:	Spare Part No:
P2	1	Carrier	-18
P4	1	Washer for V-ring seal	-03/00
P5	2	Axle seal, with stainless spring	-03/02
P6	1	Locking ring	-03/03
P7	4	Screw for end shield assembly	-23
P8	1	V-ring seal	-03/01
P9	1	Key for carrier	-10
P10	1	Rotary shredder	-02
P11	1	Axle washer	-06
P12	1	Axle screw	-07
P13	1	Stationary shredder	-01
P14	1	Seal for stationary shredder	-05
P16	4	Locking nut and washer for hood assembly	-25
P17	1	Seal for hood flange	-08
P18	6	Nut for disposer assembly	-22
<b>Not depicted parts</b>			
P19	1	Special grease for seals and carrier	-04
P20	1	Rubber sealing compound	-09
P24	1	Disassembly screw for carrier	-18/02
<b>Parts depicted on the next page</b>			
P32	1	Seal for Safety Interlock Switch	-39/01
P34	1	Seal for plug used when cleaning the inlet feeding hopper	-67
P35	2.23m 3.13m	Sealing list for 2 cabinet doors, (2.23m/door) and rear panel, 3.13m	-69







**OTHER PARTS - Parts that should be replaced as needed**

Position No:	Qty:	Denomination:	Spare Part No:
P1	1	Motor with drained upper flange	-14
P3	1	End shield	-13
P15	1	Hood	-16
<b>Not depicted parts</b>			
P21	2	Axle seal, motor drive end and motor non-drive end	-14/01
P22	2	Bearing, motor drive end and motor non-drive end	-14/02
P23	1	Key for motor shaft	-14/03
<b>Parts depicted on the next page</b>			
P25	4	Adjustable machine leg for cabinet, land installation	-29/01
P26	4	Adjustable machine leg for cabinet, marine installation	-29/02
P27	1	Jam release wrench for rotary shredder	-31
P28	1	Solenoid valve, G½" (BSPP), internal thread excl. coil, cable plug and fixating washer	-35
P29	1	Coil for solenoid valve	-36
P30	1	Line strainer, G½" (BSPP), internal thread	-37
P31	1	Safety Interlock Switch	-39
P33	1	Key for Safety Interlock Switch	-39/03
P36		Timer	-

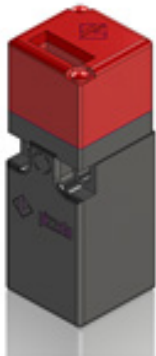
Always state machine serial number and spare part number (see above) when ordering spare parts.

**NOTE!** That the correct quality and strength of all nuts and screws used are important. Disperator can not guarantee the safety if other screws and nuts than those ordered from us are used.

<b>P17</b>	<b>P25</b>	<b>P26</b>
<b>P27</b>	<b>P28</b>	<b>P29</b>

		
<p><b>P30</b></p>	<p><b>P31</b></p>	<p><b>P32</b></p>
		
<p><b>P33</b></p>	<p><b>P34</b></p>	<p><b>P35</b></p>
		
<p><b>P36</b></p>		

### 10.3. Overhaul of Protection Cover with Switch, Assembly and Connections

The below designations within brackets refers to the position numbers on the exploded view drawing with associated spare part list of the disposer in section 10.2.

Note that the machine's rear panel is removable for easy access to the parts located at the back of the cabinet during service work.

The following checks of the machine must be done in accordance with the table in section 10.8. "Overhaul and Maintenance Intervals" – i.e. make sure that:

- the rubber seal (P32) around the protection cover key (P33) for the interlock switch (P31) is in good condition, and that the sealing surfaces are clean and undamaged. If necessary, replace the seal and clean the sealing surfaces,
- all nuts (P18) between disposer and assembly are tightend and in good condition,
- the pump is securely fixated in the cabinet,
- the hose and piping between the disposer and the pump are securely fixated and
- that there are no leaks,
- pump connection to the drain pipe is tight and fixed,
- the flushing water connection to the machine is tight and fixed,
- all cable glands are tight and fixed,
- the cabinet is securely fixated either to the wall/bulkhead or the floor/floor plate.

### 10.4. Overhaul and Maintenance of the Pump

The Original Operation and Maintenance Instruction for the pump are delivered with this machine (GTS-E65-Food Waste Processor). Note that the machine's rear panel is removable for easy access to the parts located at the back of the cabinet during service work.

## 10.5. Dismantling of Disposer

The below designations within brackets refers to the position numbers on the exploded view drawing with associated spare part list of the disposer in section 10.2.

1. Use the main electrical safety breaker on the wall/bulkhead to disconnect electrical supply, and lock the breaker with a padlock or a cable tie.
2. Disconnect the disposer motor (P1) connection cable from the AS1-electrical control box, i.e. let the cable accompany the disposer out of the cabinet.
3. Disconnect the drain hose from the outlet pipe connection on the end shield (P3).
4. Use a trolley which lifting plate can be inserted under the disposer motor in the cabinet, or alternatively a steady jack with lifting plate. Detach the disposer from the assembly under the hopper (6 nuts, P18), and remove the the disposer from the cabinet. These nuts must always be replaced before reassembly as they are locking nuts.

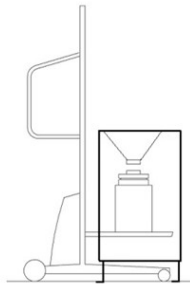

5. Loosen the 4 nuts with washers (P16). These 4 nuts must always be changed for new ones before reassembly, as they are lock nuts. Note the location of the disposer outlet on the end shield (P3) relative to the hole pattern on the hood (P15) upper side, so that the outlet later may be reassembled in the same direction. For this purpose, is also an arrow engraved on the hood lower edge, which when reassembling shall be above the outlet of the the end shield (P3). Remove the hood (P15).
6. Remove the seal (P14) on the stationary shredder. This seal must always be replaced with a new seal when reassembled.
7. Pry the stationary shredder (P13) loose from the end shield (P3) using a crowbar that levers against the large tooth on the inside rim and is supported by the rotary shredder (P10) close to one of the two shredder blades. See photo below.



8. Loosen the axle screw (P12). If the rotating shredder (P10) keeps turning, and cannot be held still manually, use a pipe wrench to hold one of its shredder blades. Alternatively, lock the rotary shredder with a screwdriver placed through one of the holes at the disposer outlet. See photo below.



- Remove the rotary shredder (P10) by placing two crowbars opposite one another under the rim of the shredder, supported by the side of the end shield (P3). See photo below.



- Remove the V-ring seal (P8) and loosen the 4 fixing screws (P7) of the end shield. Note the position of the outlet on the end shield (P3) relative to the terminal box for cable connection on the motor (P1), so that this outlet will receive the same direction when reassembling the disposer. Remove the end shield (P3).
- Inspect the washer (P4) for possible wear caused by the V-ring seal. Replace the washer if necessary.
- Turn the end shield (P3) upside down and remove the locking ring (P6) by means of a circlip pliers. With some adequate protection in between, apply pressure to the washer (P4) in order to get the two axle seals (P5) out. See photos below.



Make sure that the surface of the sealing washer (P4) remains in good condition. Examine the contact surface of the carrier (P2) for wear caused by the axle seals. There should only be two small symmetrical (barely noticeable) tracks on the carrier (P2) if it is to be reused. Replace the carrier if necessary.



- Terminate dismantling here if carrier (P2) and motor (P1) are not to be replaced. Start the reassembling of the disposer from item 5 in section 10.6. below.  
**The V-ring seal (P8) and the two axle seals (P5) with special grease (P19) together with stationary seals (P14) and (P17) must be replaced at each dismantling.**
- In Service Package 2 a removal screw (P24) is included. Use this screw on top of the carrier (P2) and screw it down. This will remove the carrier from the motor axle. If needed, use the rotary shredder (P10) as a handle to prevent the motor axle from rotating. Alternatively, hold the carrier with a pair of pliers and a soft cloth in between as shown in the photo below.



15. When changing the motor (P1), make sure that the new motor has the same classification and quality as the original. The motor must have two holes in the upper flange to allow for ventilation and drainage of water condensation (see picture below and original motor). When drilling these holes in the motor upper flange, it is important to drill at the correct angle, so that it does not penetrate into the motor winding. All replacement motors delivered by Disperator have premade drainage holes.

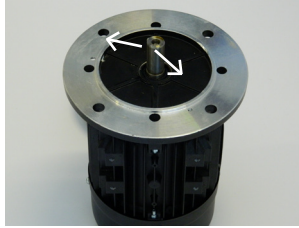

## 10.6. Assembly of Disposer

1. Clean all components carefully. Wipe the surface of the motor upper flange and its shaft (P1). Make sure that there is no dust or grease residue.
2. Make sure that the motor shaft key (P23) is in the correct position. Apply a thin layer of Disperator special grease (P19) on the motor shaft.
3. Wipe the carrier (P2) clean on the inside and outside.
4. Mark onto the motor shaft the depth of the hole in the carrier (P2). From the top of the motor shaft, this measure is 58mm for models 530A, 550A and 575A. Carefully press the carrier (P2) onto the motor shaft all the way down to the mark. If hand power is not sufficient, use the axle screw (P12) as a mounting tool. If needed, use the rotary shredder (P10) as a handle to prevent the carrier from rotating.
5. On the end shield (P3), clean the center hole for the axle seals (P5).
6. Place the washer (P4) in the end shield with the flange facing towards the motor (see the sketch below under item 8).
7. Grease the sealing face of this center hole in the end-shield (P3) with special grease (P19).
8. To avoid damaging the seals (P5, 2pcs), press each seal one at the time into position in the end shield using a tool that has the same outer diameter as these seals (see below photo). The seals shall be placed with the groove and stainless spring upwards towards the washer (P4) according to the below sketch.

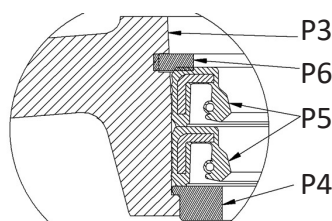

9. The seals are fixed by fitting the locking ring (P6) into the groove in the end shield (P3) according to the above sketch under item 8. Tap on this ring to ensure that it is seated properly in the groove in the end shield.
10. With a clean and soft putty knife fill the grooves along the sealing lips in the axle seals (P5) with special grease (P19). Be sure no dirt or particles happen to fall into this greasing.
11. With a clean soft cloth lubricate a thin layer of special grease (P19) on the carrier (P2) sealing surface for the axle seals (P5).

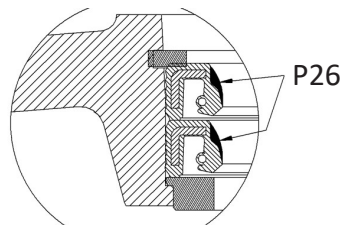

12. With reference to section 10.5, item 10 above, refit the end shield (P3) so that its outlet ends up directly above the motor (P1) terminal box for cable connection. Take great care so that the lips on the axle seals (P5, 2pcs) are not damaged. Secure the end shield with tightening torque 81 Nm on the four screws (P7).
13. Grease the sealing lip of the V-ring seal (P8) and its seal washer (P4) using special grease (P19). Fit the V-ring seal over the carrier (P2) with its seal lip against the seal washer (P4).

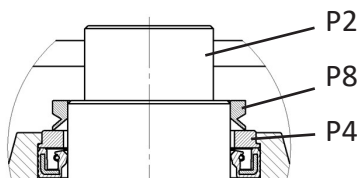

14. Insert a small click of special grease (P19) into the keyway of the carrier (P2) and push on the key (P9).
15. Wipe clean the axle hole in the rotary shredder (P10). Also make sure that the mating surfaces on the end shield (P3) and the stationary shredder (P13) are clean.
16. Carefully fit the rotary shredder (P10) on the carrier (P2).

17. Wipe the carrier (P2) clean from excess grease.
18. Apply a layer of rubber sealing compound (P20) over the joint between rotary shredder and carrier (see photo below). Make sure that no sealing compound enters the screw hole of the carrier.



19. Fit the axle washer (P11) on the rotary shredder. Apply rubber sealing compound around the underside of the entire head of the axle screw (P12) and mount this screw. Make sure that sealing compound is squeezed out around the entire circumference of the axle washer, and also around the entire head of the axle screw. The axle screw is tightened with torque 44 Nm.
20. Apply a thin uninterrupted string of rubber sealing compound (P20) in the seat of the end shield (P3) in which the stationary shredder (P13) should be pressed down.



21. Carefully position the stationary shredder (P13) with its upper large tooth closest to the outlet of the end shield (P3).
22. Tap around the top of the stationary shredder (P13) with a plastic hammer to fix it in the end shield (P3), and make sure that the stationary shredder is all the way down in the seat of the end shield.
23. Fit a new rubber seal (P14) on the top of the stationary shredder (P13). Make sure that it is centered.
24. Wipe clean the surface of the hood (P15) that faces the rubber seal (P14).
25. Carefully fit the hood (P15). For the upper hole pattern of the hood to end up in the same way as before dismantling, the outside arrow mark on the hood lower edge shall be positioned centrally above the waste outlet on the end shield (P3). This is to make sure that the disposer outlet will have the same direction towards the pump as before. Also feel with your fingers that the seal (P14) still is centered.
26. Secure the hood (P15) with 4pcs. washers and 4pcs. new unused locking nuts (P16). Tighten these nuts crosswise with tightening torque 21 Nm. After tightening, check with a blade measure that the stationary seal (P14) is properly fixed and firm between stationary shredder (P13) and hood (P15).
27. The disposer is now ready to be reassembled under the hopper in the cabinet using the same trolley with lifting plate (or the same steady jack with lifting plate) as previously used when the disposer was dismantled. Be aware of the motor power supply cable so it does not get pinched and damaged.

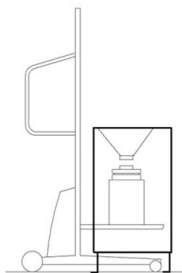

28. Make sure that the seal for the hood (P17) is placed correctly before you move the disposer into position under the hopper for mounting with 6 pcs. of new unused locking nuts (P18).

29. Reconnect the drain hose from the pump inlet to the outlet pipe on the disposer end shield (P3).
30. Reconnect the disposer motor (P1) connection cable to the AS1-electrical control box according to the electrical connection diagram supplied with the machine from Disperator.
31. Reconnect electrical supply using the main electrical safety breaker on the wall/bulkhead.
32. Start up and test the GTS-processor according to applicable start-up procedures described in section 6.5 of this user manual.

## 10.7. Timer control and Settings

### Timer control TIM-00-GT-01

*For automatic water flushing in a repetitive cycle when using pump or vacuum evacuation.*

The operator starts the processor manually by pressing the start button. Disposer, pump and flush start at the same time and the flush runs at a preset interval in repetitive cycles. The function is stopped by pressing the stop button.

The running and pausing intervals of the flushing water are adjustable.

This function is used when pumping or vacuum evacuation to a closed tank. Use of the water is thus limited to 3 to 4 liters per minute.

TIM-00-GT-01 is standard for the entire GTS series but where applicable it can be used with an externally positioned pump or with connection to a vacuum system. For vacuum systems, smaller quantities must be collected in an intermediate storage tank with a level-controlled vacuum valve. The line behind the valve has a constant vacuum.

**We can tell you more.**

Timerdrift TIM-00-GT-01, motor and control voltage must be specified when ordering.

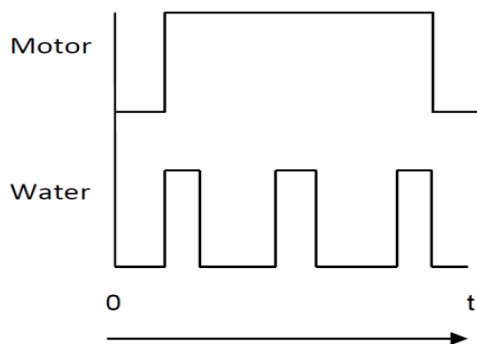

### Settings

#### TR1

a) TIMER RANGE: 1-10 min.

b) TIME SETTINGS: 2 (1 x 2 = 2 min).

c) TIMER FUNCTION: B

RUNTIME FOR DISPOSER TIME CAN BE SET FROM 0.1s - 100h.

#### TR2

##### Ton

A) TIMER RANGE: 1-10s.

RUNTIME FOR WATER FLUSHING TIME CAN BE SET FROM 0.1s - 100h.

B) TIME SETTINGS: 5 (1 x 5 = 5s).

##### Toff

C) TIMER RANGE: 6-60s

PAUSTIME FOR WATER FLUSHING TIME CAN BE SET FROM 0.1s - 100h.

D) TIME SETTINGS: 2 (6 x 2 = 12s).

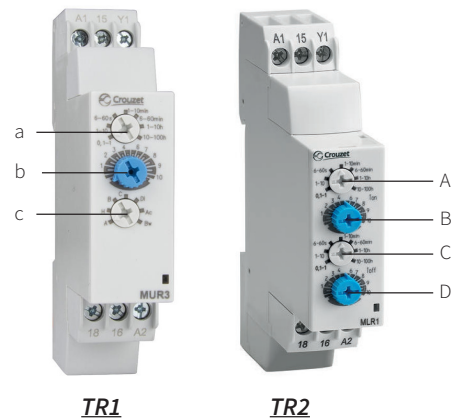

## 10.8. Overhaul and Maintenance Intervals

*For maintenance work, at least Service pack 1 is recommended.*

<b>Description:</b>	<b>Interval:</b>	<b>Refers to:</b>
Cleaning of the machine	After daily use	See section 8.2 in this user manual
Check of the line strainer in the flush water pipe	First time after a month use, then when needed	See section 8.3.2, item 3 in this user manual
General overhaul	First time after a month use, then once a year.	See section 9.3 in this user manual in terms of: <ul style="list-style-type: none"> <li>• Overhaul of protection safety,</li> <li>• Overhaul of assembly and connections,</li> <li>• Overhaul of all mechanical and electrical connections,</li> <li>• when needed, training of personal.</li> </ul>
Preventive service	Recommended every other year or if necessary.	<ul style="list-style-type: none"> <li>• General overhaul as above.</li> <li>• Servicepack 1 according to section 9.2.</li> </ul>
Replacement of parts due to wear	Recommended every three years or if necessary.	<ul style="list-style-type: none"> <li>• Preventive service as above.</li> <li>• Servicepack 2 according to section 9.2.</li> </ul>
Exchange of other parts	When needed	