

disperator® FOOD WASTE PROCESSOR

500A-GTS-E65 EXCELLENT SERIES

- Grinding and transportation of food waste to tank with the addition of minimal amounts of water
- Retains the energy content for decay and biogas production at a later stage
- Improved hygiene, working environment and ergonomics when working in a kitchen environment. The handling, storage and emptying of refuse containers is no longer necessary
- Rapid disposal of food waste with a high degree of reliability
- Easy to operate and clean
- Reduced need for transportation and lower costs for food waste collection
- Standard delivery includes the outer cabinet made of stainless steel AISI304. As option the outer cabinet are also available in acid proof stainless steel AISI316 for outdoor installation in sea water environments



Immediately and efficiently removing the heaviest part of kitchen waste – food leftovers – is a necessity in any commercial kitchen. When using the patent pending GTS-Series processor, food waste can hygienically and without any heavy lifting or manual transfer easily take care of and reduce the total amount of refuse – by volume, but above all by weight!

Food waste is fed into the inlet hopper of the machine and ground into small particles for further transport in a pipe using a unique processor pump to a sealed and odorless tank, and when full, emptied by a vacuum truck. The unique benefit of this processor technology is that the pumping of the ground food waste can be done with minimal amount of flushing water, which gives a good operating economy as the tank does not need to be emptied as often. The slurry is transported to an anaerobic digestion facility and converted into valuable renewable energy resource (i.e. biogas), and often the digested residue can also be used as fertilizer on farmland. Biogas is one of our society's most environmentally clean and desired energy forms, as fuel for cars as well as for the production of heat and electricity.

To suit existing interior and logistics within the kitchen, the processor outlet may be positioned either to the left or to the right of the infeed opening, thus giving full flexibility in planning your kitchen and possibility to fully utilize valuable space. Disperator's broad assortment of different technical solutions for source separation of food waste can be adapted to your specific kitchen and your specific working environment, regardless of size or layout, and regardless of the specific food waste handling rules in your environment!

Disperator GTS-Series processor fulfills the relevant provisions of the Machinery Directive 2006/42/EC, Low Voltage Directive 2014/35/EU and the EMC Directive 2014/30/EU.

All Disperator Excellent GTS-Series of processors have the Statement of Compliance issued by DNV GL verifying compliance with applicable sections of MARPOL Annex V REGULATIONS FOR THE CONTROL OF POLLUTION BY GARBAGE FROM SHIPS AND PLATFORMS, as amended in 2019.

Disperator AB

Mälurvägen 9, SE-141 71 Segeltorp, Sweden
Tel +46-8-724 01 60
info@disperator.se, www.disperator.se



MADE IN SWEDEN

disperator® FOOD WASTE PROCESSOR

500A-GTS-E65 EXCELLENT SERIES

Front view

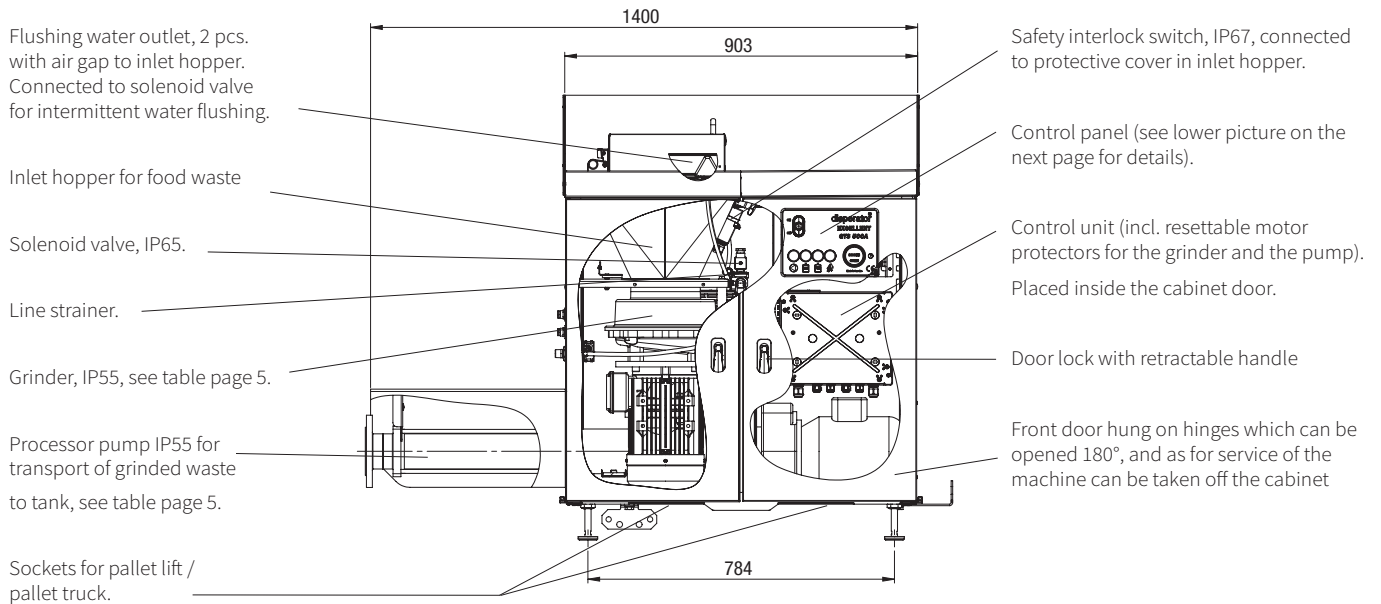

Side view

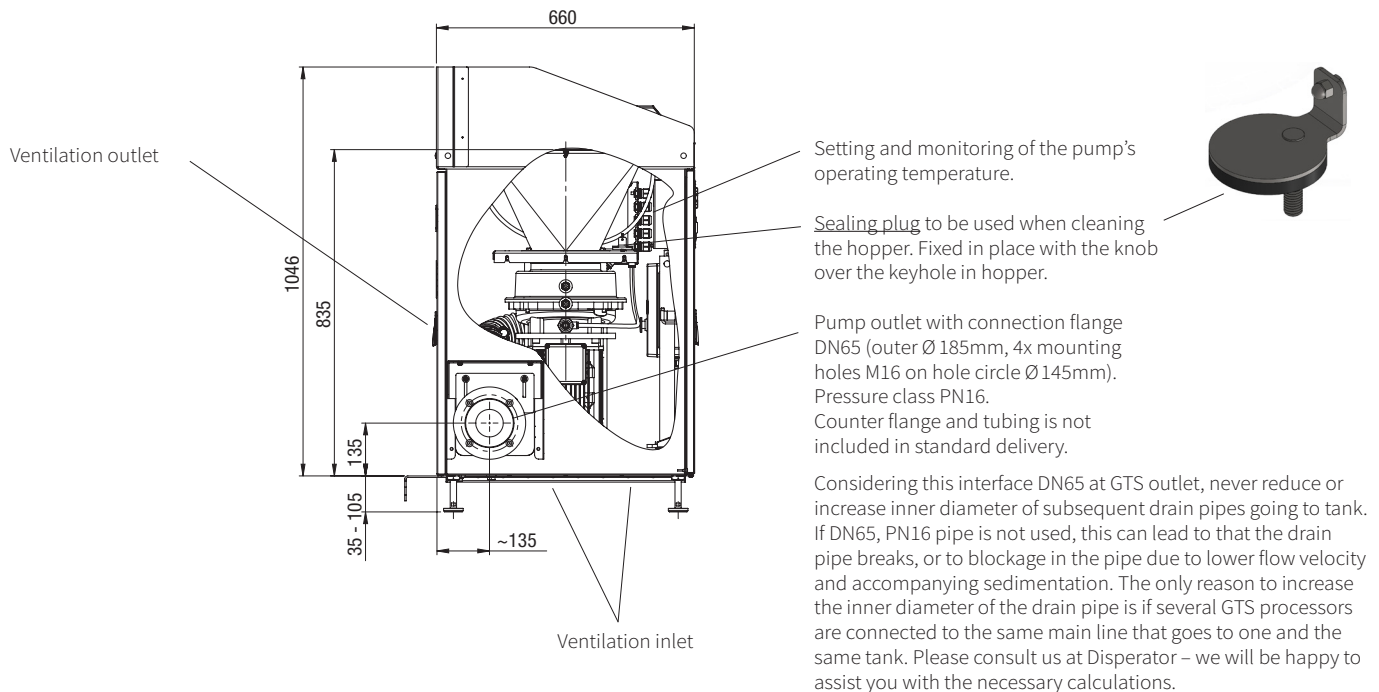

All dimensions in mm

Disperator AB

Mälarvägen 9, SE-141 71 Segeltorp, Sweden
Tel +46-8-724 01 60
info@disperator.se, www.disperator.se

Ref: 500A_GTS-E65_pb_en_260115

disperator® FOOD WASTE PROCESSOR

500A-GTS-E65 EXCELLENT SERIES

Top view

Cabinet rear panel (removable for service of the machine).

Adjustable bracket. 2 pcs. for fixing the machine against a long wall, or alternatively using 1 pc. against a long wall and 1pc. against a corner wall.

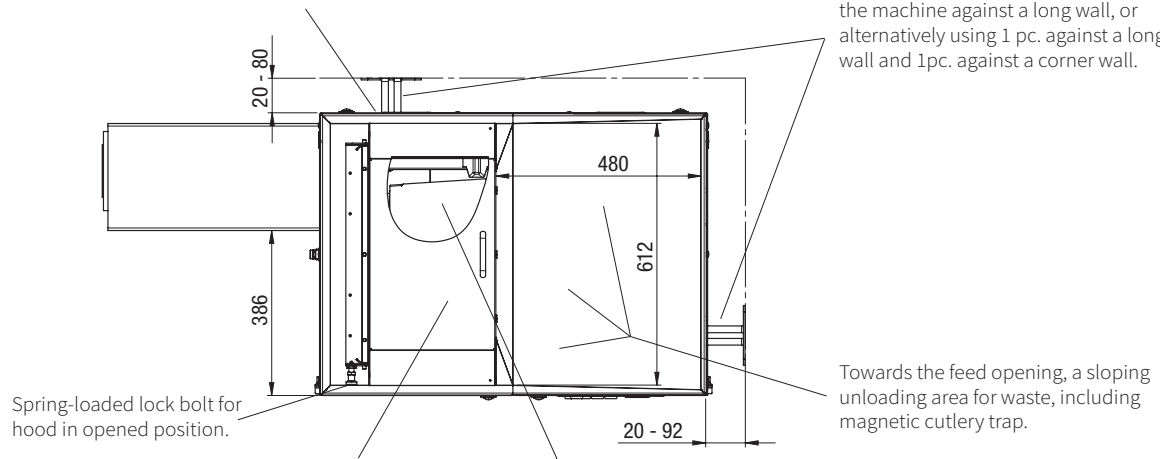

Spring-loaded lock bolt for hood in opened position.

Towards the feed opening, a sloping unloading area for waste, including magnetic cutlery trap.

Noise absorbing hood above feed opening. (Can be opened for batch emptying of receptacles with e.g. soup, sauce, etc.)

Protective cover in the feeding hopper to the disposer, linked to safety interlock switch. Removed during daily cleaning. The machine will then not start until the cover is back in place.

Top view of foot

Marine version

Land version

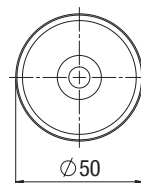
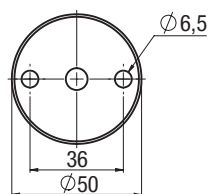

All dimensions in mm

Disperator AB

Mälarvägen 9, SE-141 71 Segeltorp, Sweden
Tel +46-8-724 01 60
info@disperator.se, www.disperator.se

Ref: 500A_GTS-E65_pb_en_260115

disperator® FOOD WASTE PROCESSOR

500A-GTS-E65 EXCELLENT SERIES

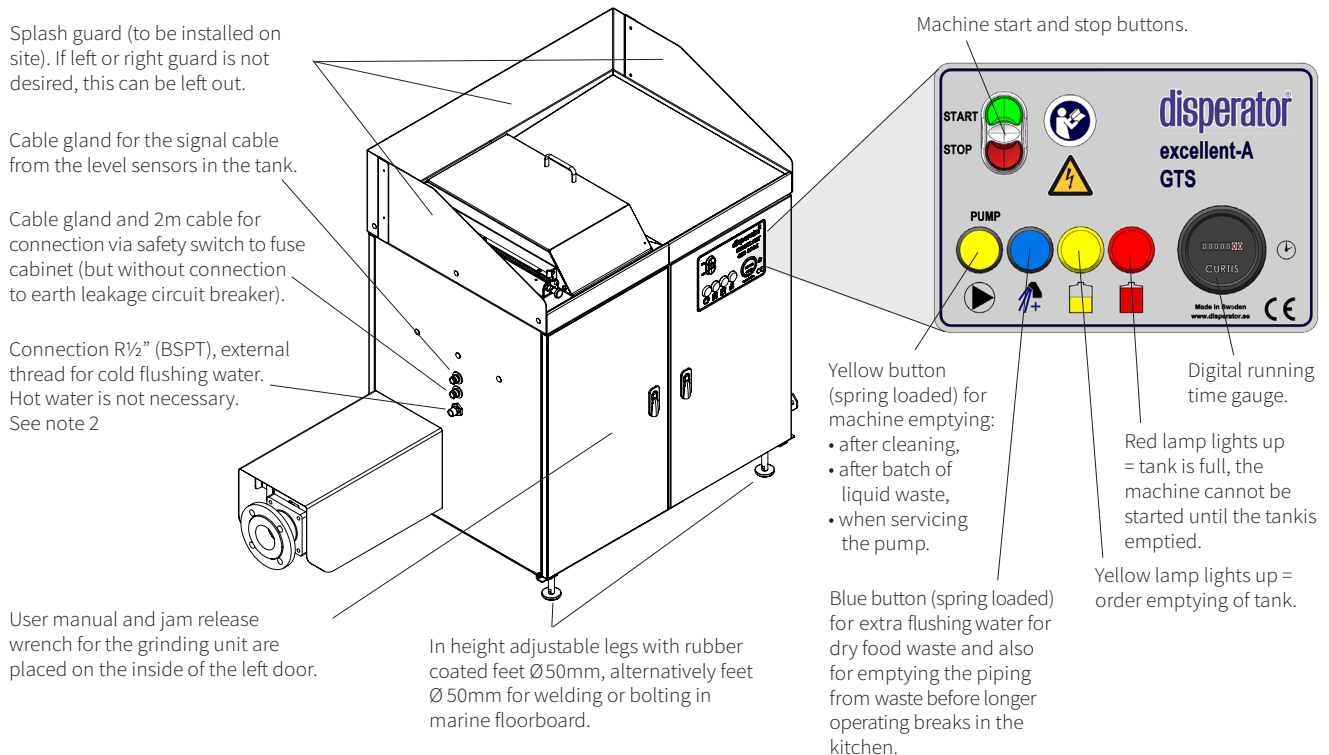

Timer control TIM-00-GT-01

For automatic water flushing in a repetitive cycle when using pump or vacuum evacuation.

- The operator starts the processor manually by pressing the start button. Disposer, pump and flush start at the same time and the flush runs at a preset interval in repetitive cycles. The function is stopped by pressing the stop button.
- The running and pausing intervals of the flushing water are adjustable.
- This function is used when pumping or vacuum evacuation to a closed tank. Use of the water is thus limited to 3 to 4 liters per minute.
- TIM-00-GT-01 is standard for the entire GTS series but where applicable it can be used with an externally positioned pump or with connection to a vacuum system. For vacuum systems, smaller quantities must be collected in an intermediate storage tank with a level-controlled vacuum valve. The line behind the valve has a constant vacuum.
We can tell you more.
- Timerdrift TIM-00-GT-01, motor and control voltage must be specified when ordering.

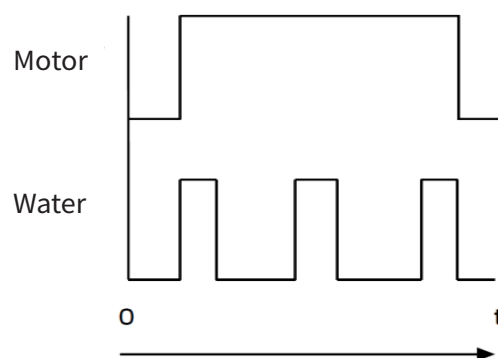

Disperator AB

Mälurvägen 9, SE-141 71 Segeltorp, Sweden
 Tel +46-8-724 01 60
 info@disperator.se, www.disperator.se

disperator[®] FOOD WASTE PROCESSOR

500A-GTS-E65 EXCELLENT SERIES

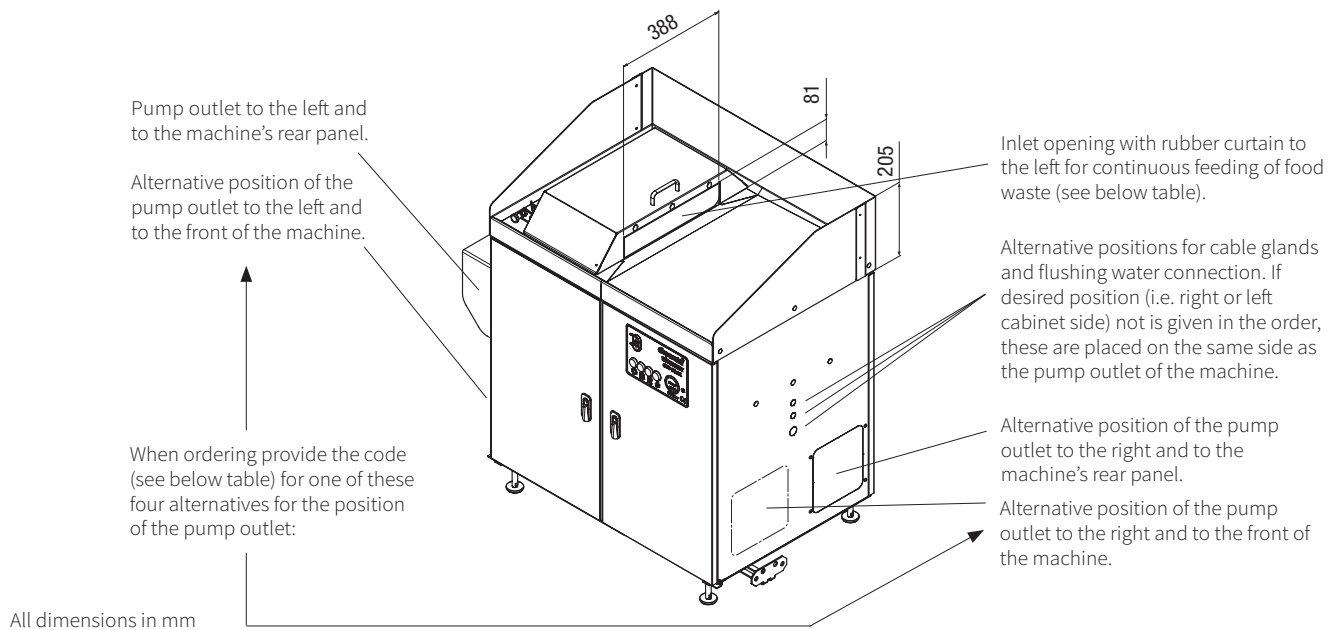

Disperator AB

Mälarvägen 9, SE-141 71 Segeltorp, Sweden
Tel +46-8-724 01 60
info@disperator.se, www.disperator.se

Ref: 500A_GTS-E65_pb_en_260115

disperator® FOOD WASTE PROCESSOR

500A-GTS-E65 EXCELLENT SERIES

Alternative	Position of the inlet opening for waste	Position of the pump outlet	Provide the following code when ordering
1*	to the left	to the left and to the machine's rear panel	VVB
3*	to the left	to the right and to the machine's rear panel	VHB
5*	to the right	to the left and to the machine's rear panel	HVB
7*	to the right	to the right and to the machine rear panel	HHB

View from above

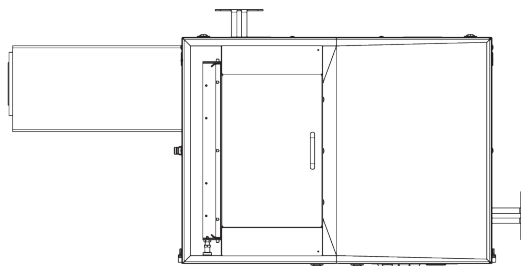

Alt. 1

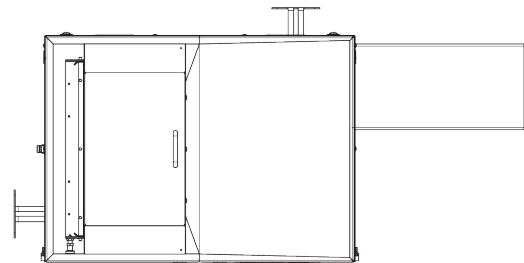

Alt. 3

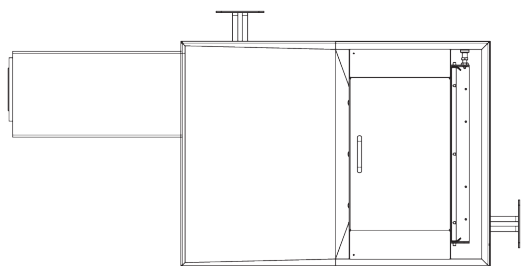

Alt. 5

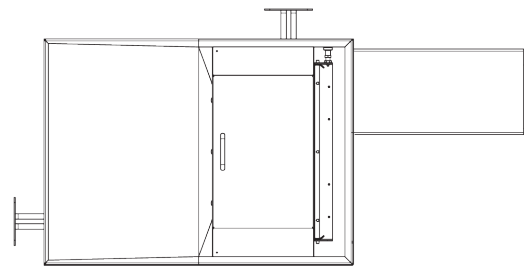

Alt. 7

Disperator AB

Mälarvägen 9, SE-141 71 Segeltorp, Sweden
Tel +46-8-724 01 60
info@disperator.se, www.disperator.se

Ref: 500A_GTS-E65_pb_en_260115

disperator[®] FOOD WASTE PROCESSOR

500A-GTS-E65 EXCELLENT SERIES

Technical specification	530A-GTS-E65	550A-GTS-E65	575A-GTS-E65
Standard capacity, liters/hr.	600	750	900
Optional capacity, liters/hr.	1400	1600	1800
Electrical power, kW (disposer+pump)	2,5+1,5	4,0+1,5	5,5+1,5
Rated current, A to be set on the two processor motor protectors for the following voltages:			
400V / 3 ph. / 50 Hz (disposer+pump)	9,1 (5,5+3,6)	12,2 (8,6+3,6)	15,1 (11,5+3,6)
440V / 3 ph. / 60 Hz (disposer+pump)	9,1 (5,5+3,6)	11,1 (7,5+3,6)	13,6 (10,0+3,6)
Control voltage	230V 50/60Hz	230V 50/60Hz	230V 50/60Hz
Fuse rating, slow	16A	16A	16A
Characteristic for automatic fuse	D (slow)	D (slow)	D (slow)
Net weight, kg	210	215	230
Processor drainage outlet	DN65	DN65	DN65
<i>Process pump pressure class:</i>			
*standard	PN16	PN16	PN16
*optional	PN10	PN10	PN10

The processor operates in the temperature range -5°C to +40°C

Note 1: Connect the machine via safety switch to fuse cabinet, but without connection to earth leakage circuit breaker.

Note 2: Recommended incoming water pressure 3 - 6 bar.

Subject to any changes without prior notice.

(1) Installation material needed but not incl. in standard delivery are:

- main electrical safety switch placed on wall/bulkhead for incoming electricity, see note 1,
- hose with protective steel-covered stocking (minimum inner -Ø 9mm) for cold flush water.

Can be ordered from DISPERATOR.

(2) User manual with installation and service instructions, laminated operating instructions and laminated safety instructions as well as electrical documentation are included in delivery.

(3) Options:

- DN65 drain valve,
- equipment for monitoring of tank level,
- waste holding tanks for indoor installation,
- waste holding tanks for installation below ground level outdoors,
- drain pipe with pressure class PN16 in plastic or stainless steel between the processor and the tank.

Disperator AB

Mälarvägen 9, SE-141 71 Segeltorp, Sweden
Tel +46-8-724 01 60
info@disperator.se, www.disperator.se

Ref: 500A_GTS-E65_pb_en_260115