

# disperator® FOOD WASTE DISPOSERS

## 500A-MI EXCELLENT SERIES

CE



Included in standard delivery



Contactor with motor protector



Jam release wrench for grinding unit

Standard delivery includes the outer disposer housing and installation assembly made of stainless steel AISI304. As option the housing with assembly are also available in acid proof stainless steel AISI316 for outdoor installation in sea water environments

Disperator food waste disposers are used in galleys and kitchens around the world, providing an efficient and immediate removal of food waste whenever it arises. Thereby improving hygiene in the working environment, eliminating bad odors and bacteria formation and minimizing manual handling.

Our product range is designed with the user's needs in focus and meets the modern requirements for handling food waste. The quality grinding unit with hardness from specially cast steel alloy, together with the unique sealing design between grinder and motor, ensure years of reliable operation and low maintenance cost. The disposer's life span is extended further by the outer housing of stainless steel EN 1.4301 (AISI 304) and protection class IP55 or higher for electrical components.

The wide range of disposer sizes make it easy to adjust any installation to fit any workplace in a galley or kitchen. The MI discharge cone allows for food waste to be collected and ground in batches when required and is welded into an existing working bench or table top. The disposer inlet is fully covered by a tight protection lid, preventing access to the

grinding unit during operation, providing a splash back protection and reducing the risk of cutlery falling into the disposer by mistake. The lid is fitted with a safety interlock switch which stops the disposer when lifted. Other features of the lid are noise reduction during operation and the possibility to be used as an extra work surface serving its purpose even where space is limited.

Standard delivery includes a complete contactor with motor overload protector to be installed at site. The cone is delivered with flushing nozzles, a solenoid valve and a line strainer already assembled for easy installation. Water will automatically flow through the nozzles when the disposer starts and flush the food waste into the grinder chamber and continue into the sewer system or connected tank.

All Disperator Excellent 500-Series of disposers have the Statement of Compliance issued by DNV GL verifying compliance with applicable sections of MARPOL Annex V REGULATIONS FOR THE CONTROL OF POLLUTION BY GARBAGE FROM SHIPS AND PLATFORMS, as amended in 2019.

### Disperator AB

Mälärvägen 9, SE-141 71 Segeltorp, Sweden  
Tel +46-8-724 01 60  
info@disperator.se, www.disperator.se



MADE IN SWEDEN

Ref: 500A\_MI\_pb\_en\_260218

# disperator® FOOD WASTE DISPOSERS

## 500A-MI EXCELLENT SERIES

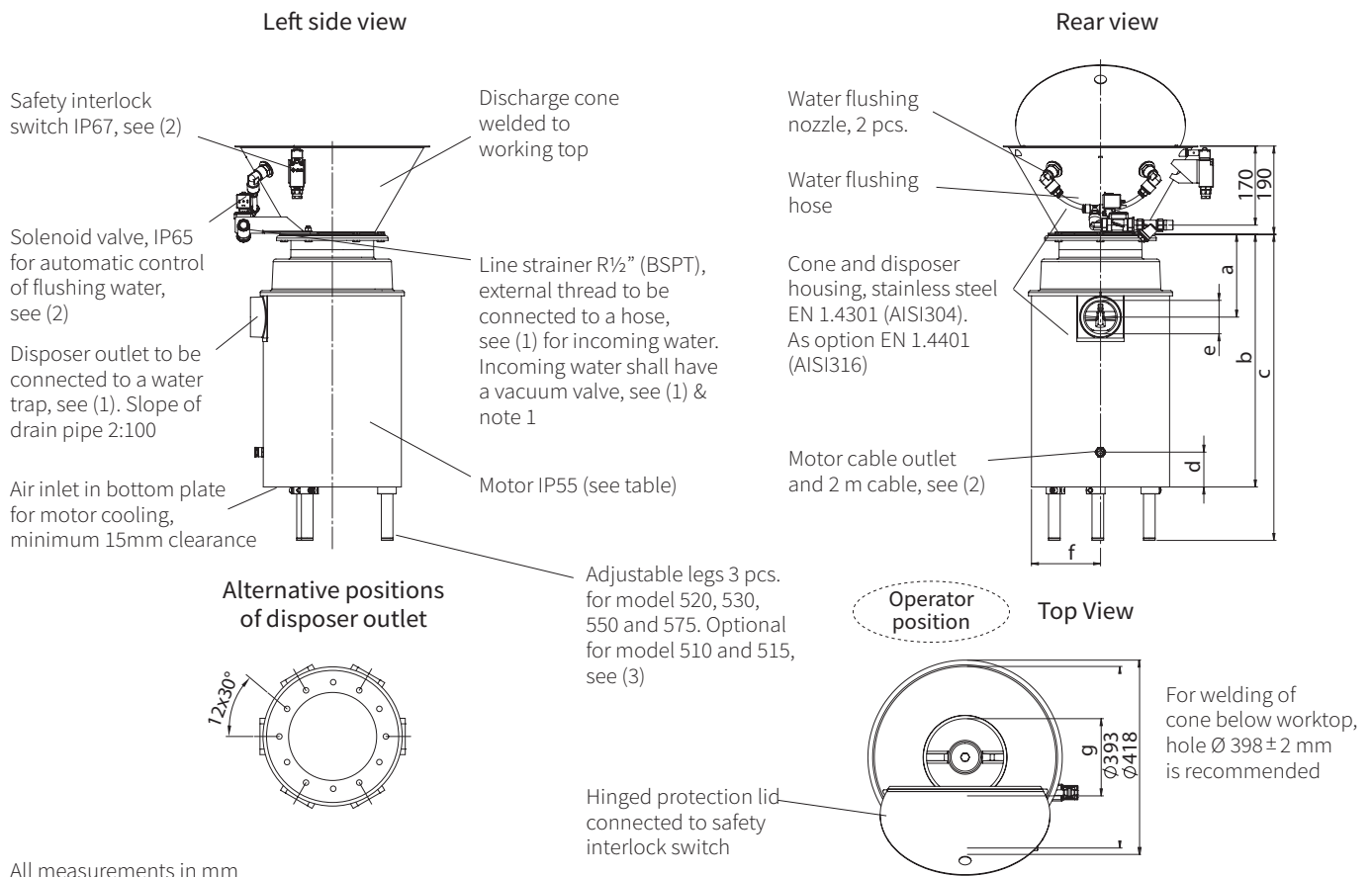

All measurements in mm

| Technical Specification  | 510A  | 515A        | 520A     | 530A                            | 550A            | 575A     |
|--|---|-------------|----------|---------------------------------|-----------------|----------|
| Normal capacity, kg/hr   | 300   | 400         | 500      | 700                             | 850             | 1000     |
| Electrical power, kW   | 0,9   | 1,25        | 1,8      | 2,5                             | 4,0             | 5,5      |
| Rated current, A to be set on the disposer motor protector for the following voltages: |   |             |          |                                 |                 |          |
| 400 V / 3 ph. / 50 Hz  | 2,2   | 2,7         | 3,7      | 5,5                             | 9,0             | 12,0     |
| 440 V / 3 ph. / 60 Hz  | 2,2   | 2,7         | 3,7      | 5,5                             | 7,5             | 10,0     |
| 480 V / 3 ph. / 60 Hz  | 2,2   | 2,7         | 3,7      | 5,0                             | 7,5             | 10,0     |
| Other 3-ph. voltages available.  |   |             |          |                                 |                 |          |
| Control voltage  | For marine installation the same as motor voltage, for land installation 230V / 50Hz. |             |          |                                 |                 |          |
| Fuse rating, slow  | 10 A  | 10 A        | 10 A     | 16 A                            | 16 A            | 16 A     |
| Characteristic for automatic fuse  | D (slow)  | D (slow)    | D (slow) | D (slow)                        | D (slow)        | D (slow) |
| Gross / net weight, kg   | 39 / 29   | 41 / 31     | 44 / 34  | 65 / 47                         | 68 / 50         | 73 / 55  |
| Measurement a  | 151   | 151         | 151      | 176                             | 176             | 176      |
| Measurement b  | 460 see (3)   | 460 see (3) | 583      | 560, see (4)                    | 560, see (4)    | 655      |
| Measurement c  | See (3)*  | See (3)*    | 583-763  | 560-740 see (4)                 | 560-740 see (4) | 655-835  |
| Measurement d  | 40  | 40          | 40       | 75                              | 75              | 75       |
| Measurement e  | G2" (BSPP), internal thread   |             |          | G2 1/2" (BSPP), internal thread |                 |          |
| Measurement f  | 127   | 127         | 127      | 155                             | 155             | 155      |
| Measurement g (legs)   | See (3)   | See (3)     | 204      | 236                             | 236             | 236      |

Note 1: Recommended incoming water pressure 3 - 6 bar.

Subject to change without notice.

- (1) Installation material needed but not incl. in standard delivery are:
    - main electrical safety switch placed on wall/bulkhead for incoming electricity,
    - hose with protective steel-covered stocking (minimum inner- $\varnothing 9$ mm) for cold flush water,
    - vacuum valve (marine installation),
    - water trap for connection to disposer outlet.
 Can be ordered from DISPERATOR.
  - (2) For connection to start/stop unit including contactor and overload protector (IP66) placed on wall/bulkhead. Start/stop unit to be connected to main electrical safety switch, see (1), but not to earth leakage circuit breaker.
  - (3) 3-ph. unit without legs as standard. Legs available as option.
  - (4) Short version (b = 525 mm and c = 525-705 mm) and long version (b = 655 mm and c = 655-835 mm) available as option.
  - (5) User manual with installation and service instructions, laminated operating instructions and laminated safety instructions as well as electrical documentation are included in delivery.
- (\*) 1-ph. unit 510A with or without legs from 460-763 mm.  
 3-ph. unit 510A with or without legs from 460-763 mm.  
 1-ph. unit 515A with or without legs from 583-763 mm.

### Disperator AB

Mälärvägen 9, SE-141 71 Segeltorp, Sweden  
 Tel +46-8-724 01 60  
 info@disperator.se, www.disperator.se

Ref: 500A\_MI\_pb\_en\_260218