

disperator® FOOD WASTE DISPOSERS

500A-UK EXCELLENT SERIES



Included in standard delivery

Contactor with motor protector

Water flushing gooseneck

Jam release wrench for grinding unit

Standard delivery includes the outer disposer housing and installation assembly made of stainless steel AISI304. As option the housing with assembly are also available in acid proof stainless steel AISI316 for outdoor installation in sea water environments

Disperator food waste disposers are used in galleys and kitchens around the world, providing an efficient and immediate removal of food waste whenever it arises. Thereby improving hygiene in the working environment, eliminating bad odors and bacteria formation and minimizing manual handling.

The wide range of disposer sizes makes it easy to adjust any installation to fit any workplace in a galley or kitchen. The UK discharge cone permits continuous feeding of waste into the disposer and is welded into an existing working bench or table top. The disposer inlet is partly covered by a labyrinth protection guard preventing accidental access to the grinding unit during operation. The guard is fitted with a safety interlock switch which stops the disposer when lifted.

Standard delivery includes a complete contactor with motor overload protector to be installed at site. The cone is delivered with a flushing gooseneck, a solenoid valve and a line strainer. Cold water will automatically flow through the gooseneck when the disposer starts and flush the food waste into the grinder chamber and continue into the sewer system or connected tank.

All Disperator Excellent 500-Series of disposers have the Statement of Compliance issued by DNV GL verifying compliance with applicable sections of MARPOL Annex V REGULATIONS FOR THE CONTROL OF POLLUTION BY GARBAGE FROM SHIPS AND PLATFORMS, as amended in 2019.

Disperator AB

Mälärvägen 9, SE-141 71 Segeltorp, Sweden
Tel +46-8-724 01 60
info@disperator.se, www.disperator.se



MADE IN SWEDEN

Ref: 500A_UK_pb_en_260218

disperator® FOOD WASTE DISPOSERS

500A-UK EXCELLENT SERIES

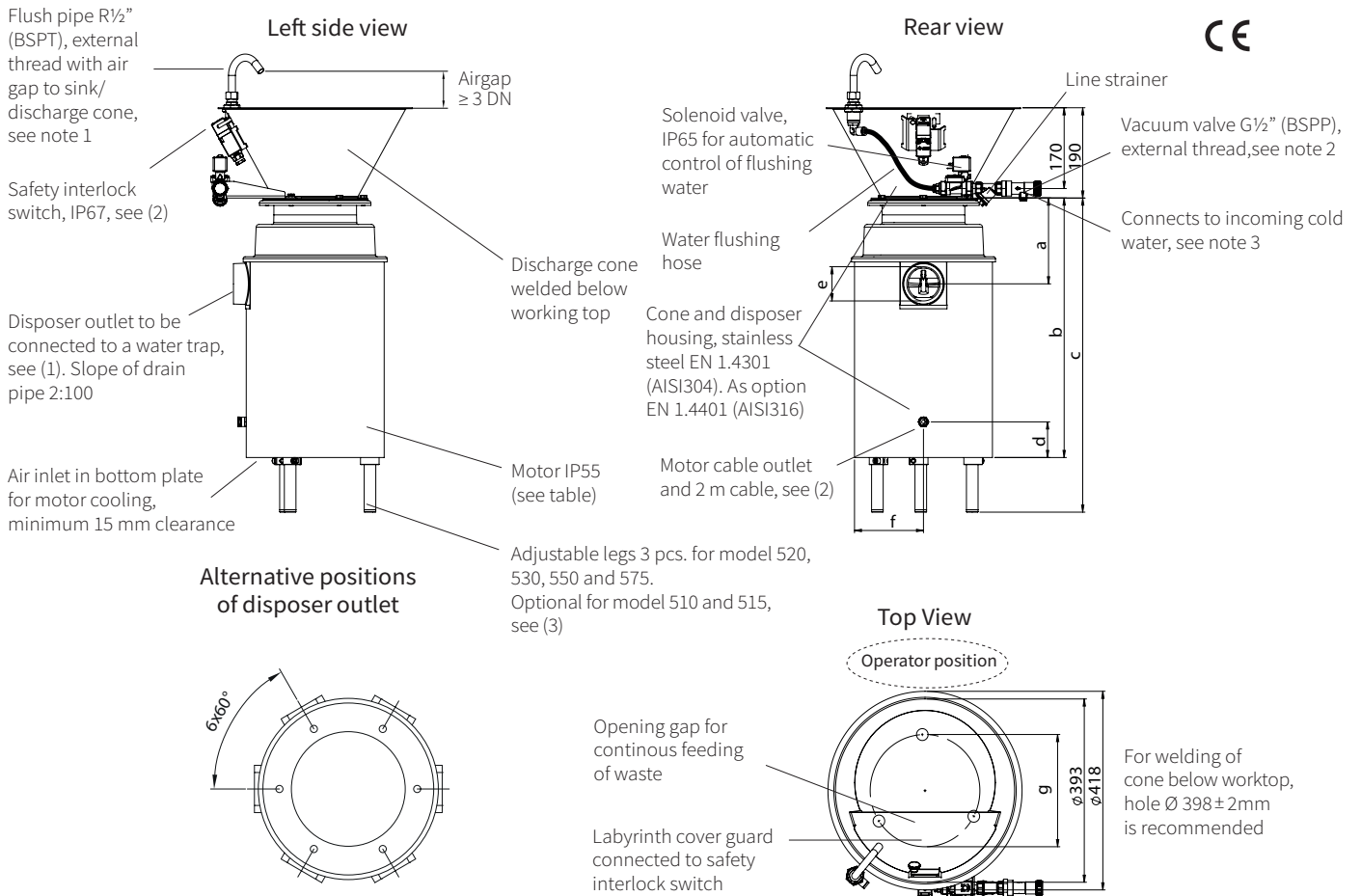

All measurements in mm

Technical Specification	510A	515A	520A	530A	550A	575A
Normal capacity, kg/hr	300	400	500	700	850	1000
Electrical power, kW	0,9	1,25	1,8	2,5	4,0	5,5
Rated current, A to be set on the disposer motor protector for the following voltages:						
400V / 3ph. / 50Hz	2,2	2,7	3,7	5,5	9,0	12,0
440V / 3ph. / 60Hz	2,2	2,7	3,7	5,5	7,5	10,0
480V / 3 ph. / 60 Hz	2,2	2,7	3,7	5,0	7,5	10,0
Other 3-ph. voltages available.	1-ph. 220-240V, 50/60Hz also available for models 510A and 515A					
Control voltage	For marine installation the same as motor voltage. For land installation 230V / 50Hz.					
Fuse rating, slow	10 A	10 A	10 A	16 A	16 A	16 A
Characteristic for automatic fuse	D (slow)	D (slow)	D (slow)	D (slow)	D (slow)	D (slow)
Gross / net weight, kg	39 / 29	41 / 31	44 / 34	65 / 47	68 / 50	73 / 55
Measurement a	151	151	151	176	176	176
Measurement b	460 see (3)	460 see (3)	583	560 see (4)	560 see (4)	655
Measurement c	See (3)*	See (3)*	583-763	560-740 see (4)	560-740 see (4)	655-835
Measurement d	40	40	40	75	75	75
Measurement e	G2" (BSPP), internal thread			G2 1/2" (BSPP), internal thread		
Measurement f	127	127	127	155	155	155
Measurement g (legs)	See (3)	See (3)	204	236	236	236

(1) Installation material needed but not incl. in standard delivery are:

- main electrical safety switch placed on wall/bulkhead for incoming electricity,
 - hose with protective steel-covered stocking (minimum inner- $\varnothing 9$ mm) for cold flush water,
 - vacuum valve (marine installation),
 - water trap for connection to disposer outlet.
- Can be ordered from DISPERATOR.

(2) For connection to start/stop unit including contactor and overload protector (IP66) placed on wall/bulkhead. Start/stop unit to be connected to main electrical safety switch, see (1), but not to earth leakage circuit breaker.

(3) 3-ph. unit without legs as standard. Legs available as option.

(4) Short version (b = 525 mm and c = 525-705 mm) and long version (b = 655 mm and c = 655-835 mm) available as option.

(5) User manual with installation and service instructions, laminated operating instructions and laminated safety instructions as well as electrical documentation are included in delivery.

(*) 1-ph. unit 510A with or without legs from 460-763 mm. 3-ph. unit 510A with or without legs from 460-763 mm. 1-ph. unit 515A with or without legs from 583-763 mm.

Note 1: Meeting the requirements as backflow protection for liquid category 5 in EN1717.

Note 2: For marine installations with flushing nozzles in sink/discharge cone, without specified rectangular overflow drain and air gap up to the flushing nozzles, which is required according to SS-EN1717 for liquid category 5.

Note 3: Recommended incoming water pressure 3 - 6 bar.

Subject to change without notice.

Disperator AB

Mälärvägen 9, SE-141 71 Segeltorp, Sweden
Tel +46-8-724 01 60
info@disperator.se, www.disperator.se

Ref: 500A_UK_pb_en_260218