

# disperator® FOOD WASTE DISPOSERS

## 500RS-BASIC EXCELLENT SERIES



**Included in standard delivery**



Contactor with motor protector



Solenoid valve



Jam release wrench for grinding unit



Line strainer

Standard includes the outer disposer housing and installation assembly made of acid proof stainless steel EN1.4401 / AISI316.

As standard the 500RS-Series are delivered for flushing with fresh water during operation, but can also as option be offered for flushing with sea water.

Disperator food waste disposers are used in galleys and kitchens around the world, providing an efficient and immediate removal of food waste whenever it arises. Thereby improving hygiene in the working environment, eliminating bad odors and bacteria formation and minimizing manual handling.

Our product range is designed with the user's needs in focus and meets the modern requirements for handling food waste. The quality grinding unit with hardness from specially cast steel alloy, together with the unique sealing design between grinder and motor, ensure years of reliable operation and low maintenance cost. The disposer's life span is extended further by the outer housing of acid proof stainless steel EN 1.4401 (AISI 316) and protection class IP55 or higher for electrical components.

The wide range of disposer sizes and its exceptional modular choice of mounting assemblies make it easy to adjust any installation to fit any workplace in a galley or kitchen. The Excellent Series disposers may be installed under sinks and washing lines, into table

tops and working benches or as freestanding as separate units. Installation into an existing assembly manufactured by another supplier is also possible.

Datasheet describing Disperator assembly above the disposer inlet (which is necessary to comply with the EU Machine Directive and CE-marking) is sent on request.

Standard delivery includes a complete contactor with motor overload protector, and a complete solenoid valve with line strainer, to be installed at site. Cold water will automatically flow through a nozzle when the disposer starts and flush the food waste into the grinder chamber and continue into the sewer system or connected tank.

All Disperator Excellent 500-Series of disposers have the Statement of Compliance issued by DNV GL verifying compliance with applicable sections of MARPOL Annex V REGULATIONS FOR THE CONTROL OF POLLUTION BY GARBAGE FROM SHIPS AND PLATFORMS, as amended in 2019.

### Disperator AB

Mälärvägen 9, SE-141 71 Segeltorp, Sweden  
Tel +46-8-724 01 60  
info@disperator.se, www.disperator.se



Ref: 500RS\_BAS\_pb\_en\_260218

# disperator® FOOD WASTE DISPOSERS

## 500RS-BASIC EXCELLENT SERIES

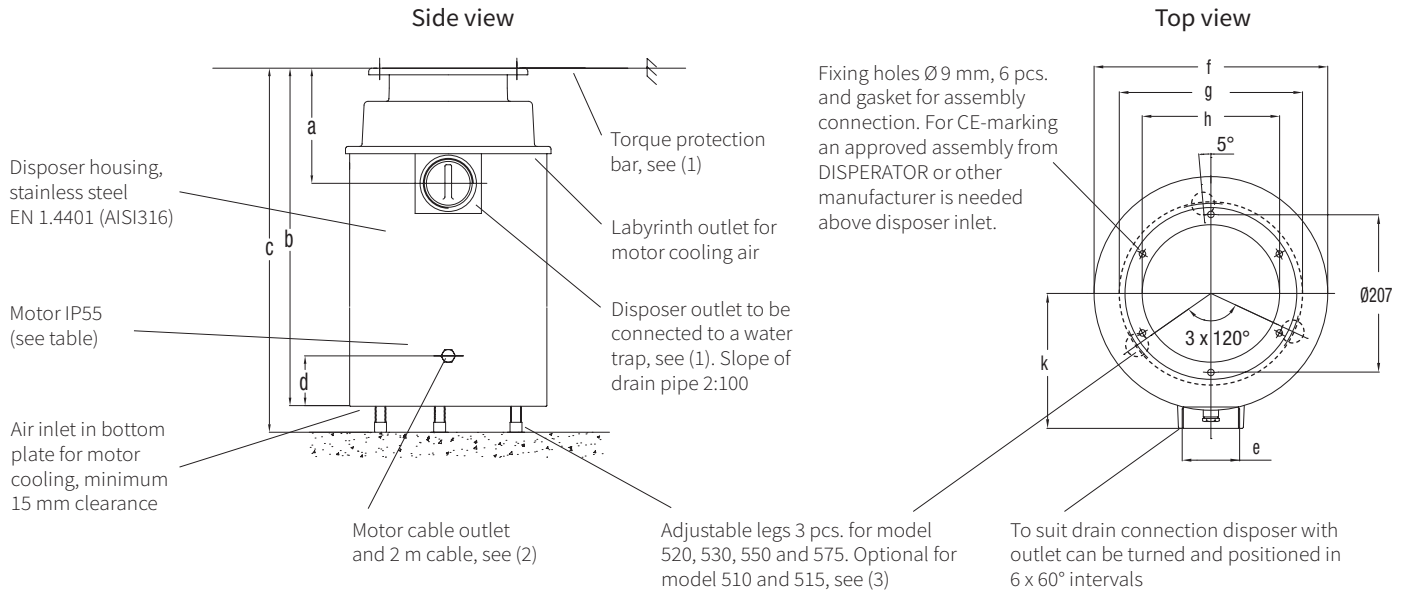

All measurements in mm

Technical Specification	510RS	515RS	520RS	530RS	550RS	575RS
Normal capacity, kg / hr	300	400	500	700	850	1000
Electrical power, kW	0,9	1,25	1,8	2,5	4,0	5,5
Rated current, A to be set on the disposer motor protector for the following voltages:						
400 V / 3 ph. / 50 Hz	2,2	2,7	3,7	5,5	9,0	12,0
440 V / 3 ph. / 60 Hz	2,2	2,7	3,7	5,5	7,5	10,0
480 V / 3 ph. / 60 Hz	2,2	2,7	3,7	5,0	7,5	10,0
Other 3-ph. voltages available.	1-ph. 220-240V, 50/60Hz also available for models 510A and 515A					
Control voltage	For marine installation the same as motor voltage, for land installation 230V / 50Hz.					
Fuse rating, slow	10 A	10 A	10 A	16 A	16 A	16 A
Characteristic for automatic fuse	D (slow)	D (slow)	D (slow)	D (slow)	D (slow)	D (slow)
Gross / net weight, kg	27 / 22	29 / 24	32 / 27	53 / 40	56 / 43	61 / 48
Measurement a	151	151	151	176	176	176
Measurement b	460 see (3)	460 see (3)	583	560 see (4)	560 see (4)	655
Measurement c	See (3)*	See (3)*	583-763	560-740 see (4)	560-740 see (4)	655-835
Measurement d	40	40	40	75	75	75
Measurement e	G2" (BSPP), internal thread			G2 ½" (BSPP), internal thread		
Measurement f	253	253	253	310	310	310
Measurement g (leg)	See (3)	See (3)	204	236	236	236
Measurement h (inlet)	160	160	160	174	174	174
Measurement k	150	150	150	176	176	176

Subject to change without notice

(1) Installation material needed but not incl. in standard delivery are:

- main electrical safety switch placed on wall/bulkhead for incoming electricity,
- hose with protective steel-covered stocking (minimum inner-Ø9mm) for cold flush water,
- vacuum valve (marine installation),
- water trap for connection to disposer outlet,
- torque protection bar, for fixing disposer to wall/bulkhead.

Can be ordered from DISPERATOR.

(2) For connection to start/stop unit including contactor and overload protector (IP66) placed on wall/bulkhead. Start/stop unit to be connected to main electrical safety switch, see (1), but not to earth leakage circuit breaker.

(3) 3-ph. unit without legs as standard. Legs available as option.

(4) Short version (b = 525 mm and c = 525-705 mm) and long version (b = 655 mm and c = 655-835 mm) available as option.

(5) User manual with installation and service instructions, laminated operating instructions and laminated safety instructions as well as electrical documentation are included in delivery.

(\*) 1-ph. unit 510A with or without legs from 460-763 mm.  
3-ph. unit 510A with or without legs from 460-763 mm.  
1-ph. unit 515A with or without legs from 583-763 mm.

## Disperator AB

Mälärvägen 9, SE-141 71 Segeltorp, Sweden  
Tel +46-8-724 01 60  
info@disperator.se, www.disperator.se

Ref: 500RS\_BAS\_pb\_en\_260218